

BENETEAU®



OWNER'S MANUAL
BENETEAU 50

SUMMARY:

I) INTRODUCTION 3
II) IDENTITY CARD OF THE BOAT 4
III) ACCOMMODATION 6
IV) DECK (Location of the life raft) 10
V) SAILS AND RIGGING 11
VI) FRESH WATER SYSTEM 18
VII) BILGE PUMP SYSTEM 20
VIII) SEACOCKS AND SKIN FITTINGS 22
IX) ELECTRIC SYSTEMS 24
X) GAS SYSTEM 33
XI) EMERGENCY SYSTEM OF THE STEERING SYSTEM 36
XII) MOTORIZATION 37
XIII) HANDLING 39
XIV) MAINTENANCE 40
XV) ENVIRONMENT 43

EXPLANATION OF THE TYPOGRAPHY USED:

DANGER

WARNING

TAKE CARE

RECEIPT

OWNER'S NAME

ADDRESS

.....

.....

Owner of the BENETEAU 50 n°

Do certify that I have accepted delivery and read the information in the owner's manual delivered with the boat.

On

Signature

Please keep this copy for your records



RECEIPT

OWNER'S NAME :

ADDRESS :

.....

.....

Owner of the BENETEAU 50 n°

Do certify that I have taken delivery and read the information in the owner's manual delivered with the boat.

On

Signature

Please send back this copy to BENETEAU S.A
ZI des Mares BP66
85270 Saint Hilaire de Riez
FRANCE

I) INTRODUCTION

Dear Madam, Dear Sir,

You have just taken delivery of your new BENETEAU boat and we would like to congratulate you first of all for the confidence you showed to us in choosing a product of our mark.

A BENETEAU boat is built to last : each boat is subject to particular care in the slightest details, as early as when she is designed, when she leaves the factory and she is launched ; this way, she will come up to your expectations for many years.

This manual was meant to help you to enjoy your boat safely. You will find in it the details of your boat , her fittings and information about the use and maintenance. Read it carefully and get to know her before you put out to sea.

If this is your first boat, or if you change to a new type of boat (to which you are not used) get some training to control and sail her , to ensure your safety and comfort. Then you will be able to assume the command of the boat. Your dealer, your national sailing association or your Yacht club will be very happy to recommend you local sailing schools or professional instructors.

Have fine and safe sailing time.

(1) Throughout their lives, our boats are regularly improved and benefit from our experience and our customers' experience ; therefore the specifications given in this owner's manual are not contractual and may be modified without prior notice and up dating obligation.

In the same way, this manual has a general purpose and it may sometimes list some equipments or refer to some points which are not relevant to your own boat. In case of doubt, you shall always refer to the inventory list.

<p>KEEP THIS MANUAL IN A SAFE PLACE AND HAND IT OVER TO THE NEW OWNER IF YOU SELL THE BOAT.</p>

II) IDENTITY CARD OF THE BOAT

Type..... BENETEAU 50
 Name of Builder CHANTIERS BENETEAU SA
 Design Category A
 N° of acknowledged body CE 0607

Length of Hull	14.90 m
Over All Beam	4.48 m
Draught: Shallow	1.80 m
Deep	2.30 m
Head Room	19.30 m

Maximum Authorized Engine Power :	72 kW
-----------------------------------	-------

Fuel capacity :	500 L
Fresh water capacity :	1000 L
Batteries capacity :	1x95 + 3x124 Amps

Category	Height of wave (m)	Wind force (Beaufort)
A	> 4	> 8
B	< 4	≤ 8
C	< 2	≤ 6
D	< 0.5	≤ 4

For additional informations concerning the fitted equipments, please refer to their manuals enclosed in the boat literature.

Maximum recommended number of persons on board by design category:

Category	Maximum number of persons
A	12
B	12
C	14
D	14

The equipments of the C.E. Certified boat are : The fuel tanks, the parts of the steering system, the parts of the gas system and the hatches and portholes.

(1)

WEIGHT ESTIMATION

SAILING CATEGORIES	A	B	C	D
Light Boat :	13000	13000	13000	13000
Safety Equipment :	154	154	154	154
Sail :	96	96	96	96
Light Displacement :	13250	13250	13250	13250
Minimum Crew :	150	150	150	150
Life Raft :	126	126	126	126
Rest of Crew :	750	750	900	900
Water :	1000	1000	1000	1000
Fuel :	204	204	204	204
Personal Equipment:	250	250	250	250
Optional Equipment	750	750	550	550
Holding Tank :	200	200	0	0
Air Conditioning :	40	40	40	40
Desalinator :	20	20	20	20
Generator :	230	230	230	230
Auto Pilot Gear :	20	20	20	20
Electric Winch :	40	40	40	40
Radar :	20	20	20	20
Bow Thruster :	40	40	40	40
Spinnaker Rigging :	10	10	10	10
Dishwasher :	20	20	20	20
Micro-Wave Oven :	10	10	10	10
Roof Sprayhood :	20	20	20	20
Bimini Top :	30	30	30	30
Davits:	50	50	50	50

MAXIMUM LOAD DISPLACEMENT (Kg)	16530	16530	16530	16530
---------------------------------------	--------------	--------------	--------------	--------------

MAXIMUM LOAD (Kg)	3280	3280	3280	3280
--------------------------	-------------	-------------	-------------	-------------

MAXIMUM LOAD = MAXIMUM LOAD DISPLACEMENT – LIGHT DISPLACEMENT

ANY OVERLOADING CARRIES A RISK OF FLOODING OR LOSS OF STABILITY

III) ACCOMMODATION

2 AFT CABIN, 1 FORWARD BERTH ON PORTSIDE VERSION
CHART TABLE ON STARBOARD

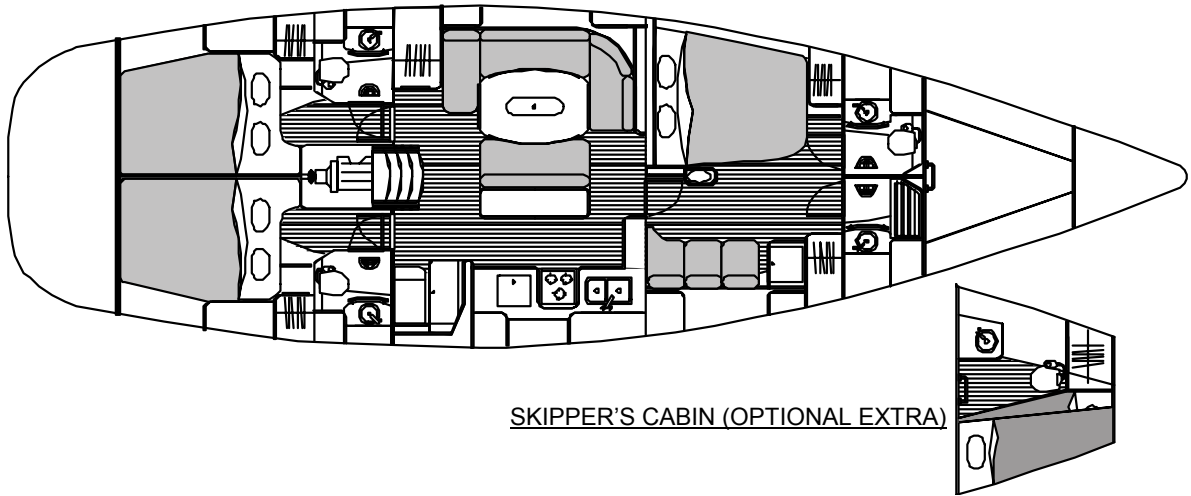

2 AFT CABIN, 1 FORWARD BERTH ON PORTSIDE VERSION
CHART TABLE ON PORTSIDE

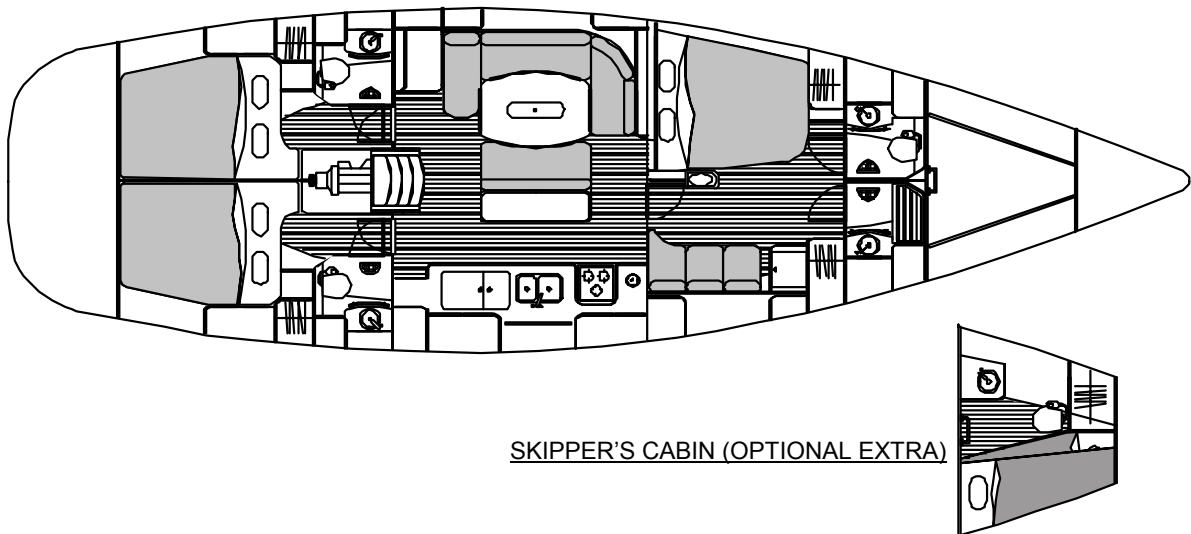

2 AFT CABIN, 1 CENTRAL FORWARD BERTH VERSION
CHART TABLE ON STARBOARD

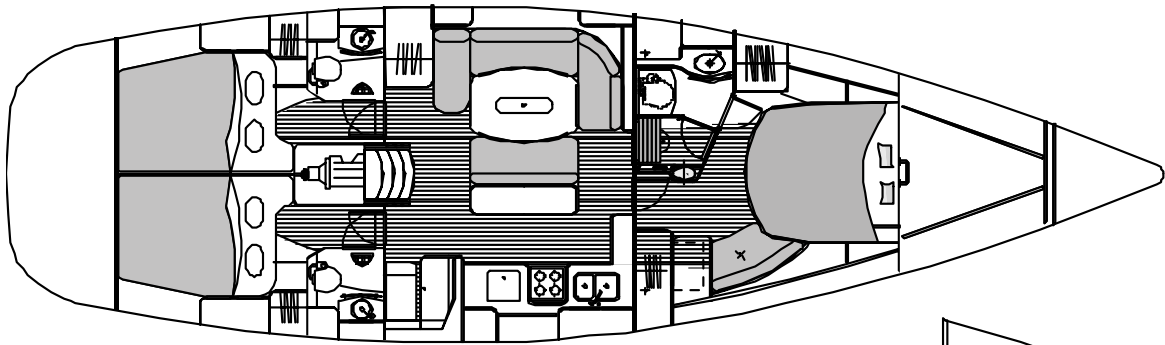

SKIPPER'S CABIN (OPTIONAL EXTRA)

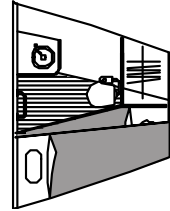

2 AFT CABIN, 1 CENTRAL FORWARD BERTH VERSION
CHART TABLE ON PORTSIDE

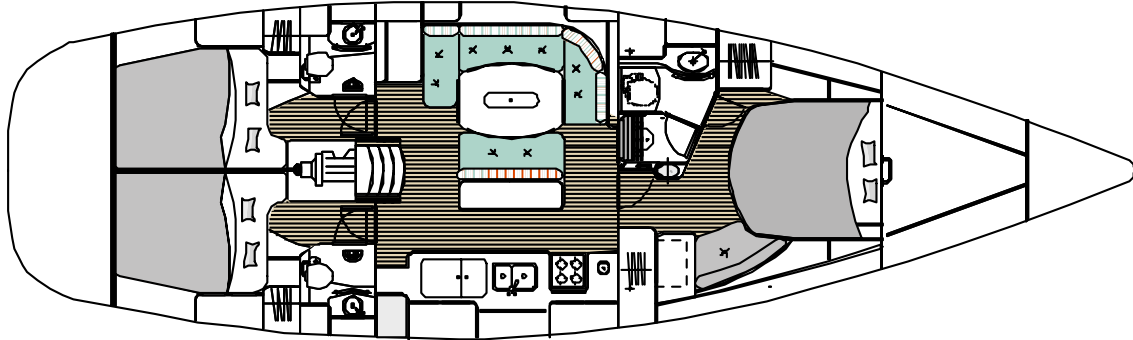

SKIPPER'S CABIN (OPTIONAL EXTRA)

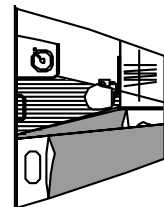

4 CABIN VERSION
CHART TABLE ON STARBOARD

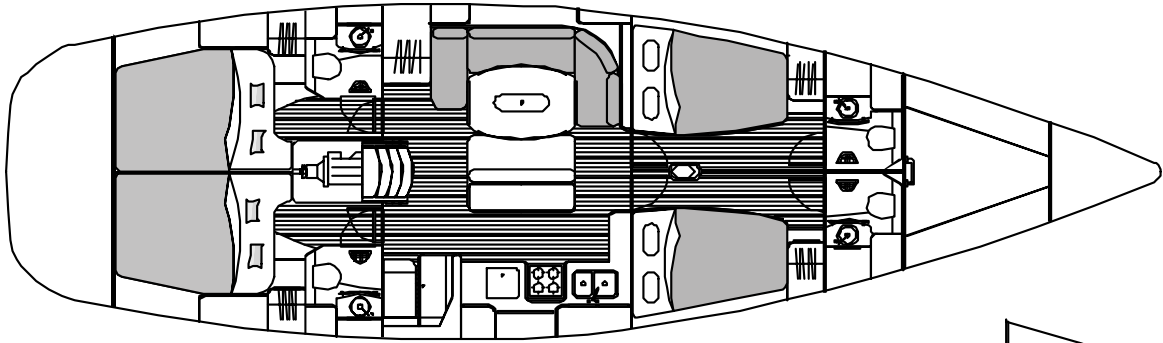

SKIPPER'S CABIN (OPTIONAL EXTRA)

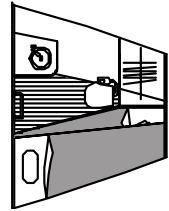

4 CABIN VERSION
CHART TABLE ON PORTSIDE

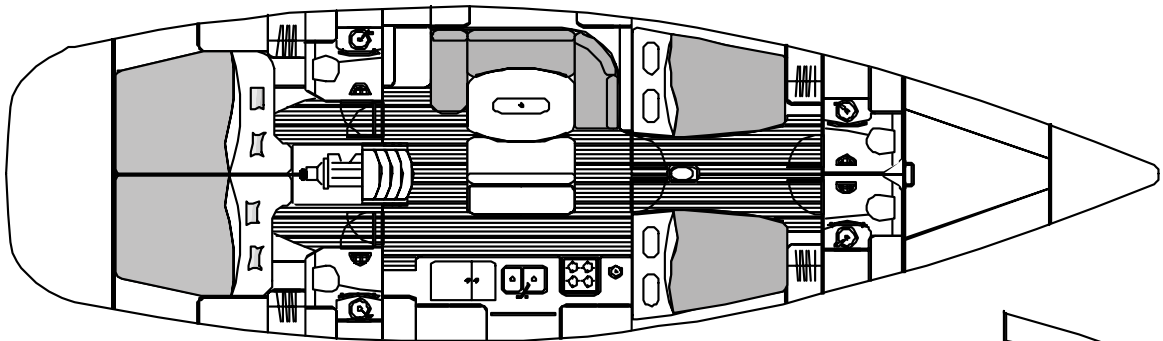

SKIPPER'S CABIN (OPTIONAL EXTRA)

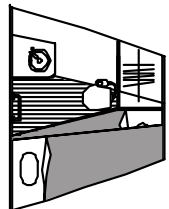

EXIT IN CASE OF FIRE

 = Recommended Exit

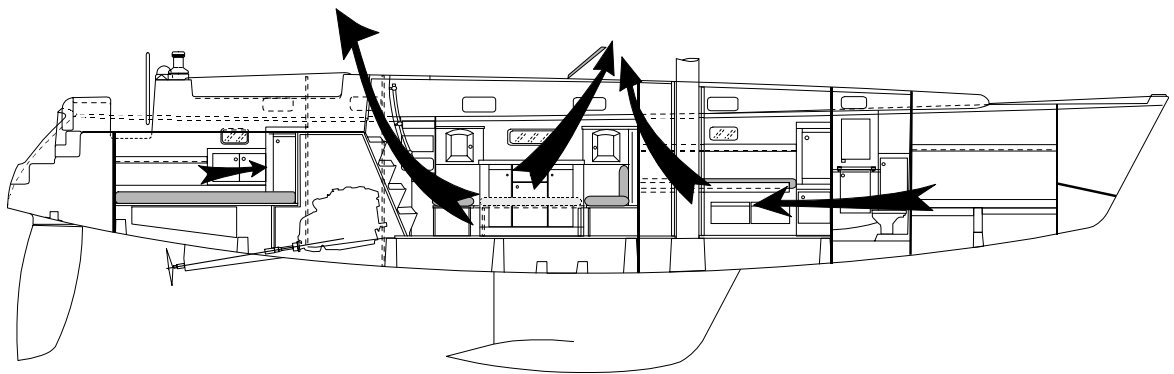

IV) DECK

- The safe lines can be fastened either on the mooring cleats or on the toe rail.

Some boats are fitted with a foldaway swimming ladder. The swimming ladder shall be in its usual place as soon as you are on board.

Make sure that the hatches and portholes are closed before you put out to sea.

In case of rough sea, close the boat with her door and washboard so that no water may come into the boat

Check that nothing blocks up the draining holes ; never seal them.

① Location of the life-raft

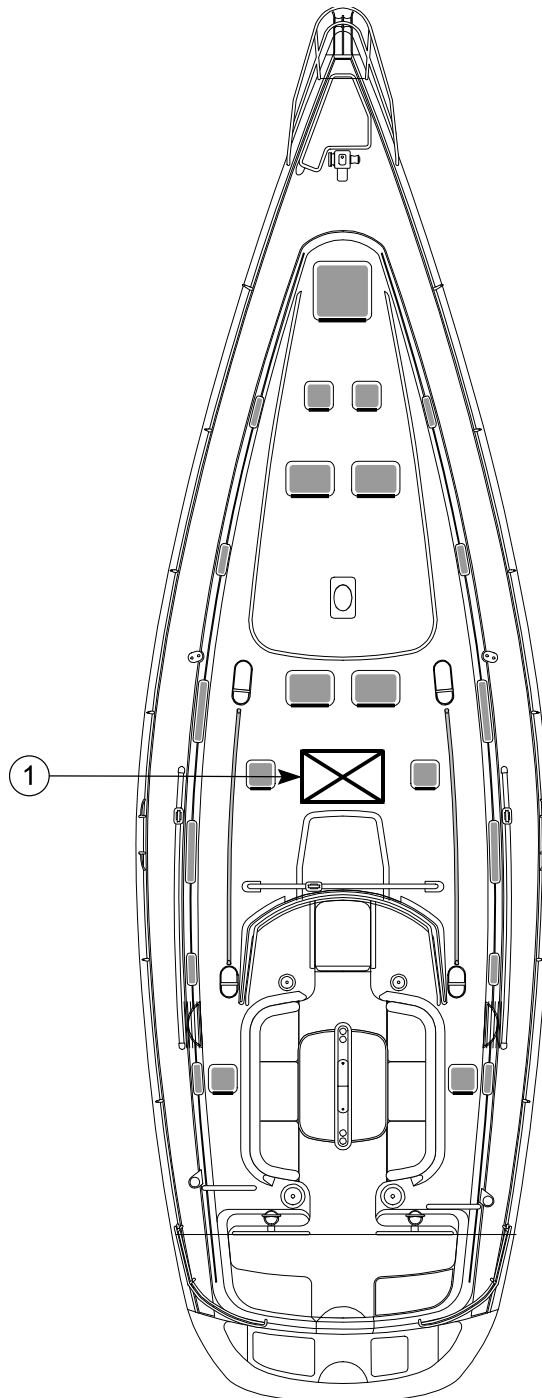

V) SAILS AND RIGGINGSpecifications of the Standing Rigging

V : Vertical – D : Diagonal

REF.	CABLE	Ø mm
1	V1 (Shroud)	14
2	D1 AFT (Lower Shroud)	12.7
3	V2 (Upper Shroud)	12
4	D2 (Inter)	8

REF.	CABLE	Ø mm
5	Forestay	12
6	Double Preventer Backstay	10
7	Baby Stay	10

Specifications of the Sails :STANDARD CLASSICAL MAST

SAIL	AREA m ²
Total	128.60 m ²
Main Sail	48.60 m ²
Genoa (maxi)	80 m ²

I	17.69 m
J	6.05 m
P	15.50 m
E	5.40 m
LP	9.13 m

Specifications of the Sails : IN-MAST FURLER (OPTIONAL EXTRA)

SAIL	AREA m ²
Total	125.40 m ²
Mainsail	45.40 m ²
Genoa (Maxi)	80 m ²

I	17.69 m
J	6.05 m
P	15.50 m
E	5.85 m
LP	7.30 m

Specifications of the sails : SPORT MAST (OPTIONAL EXTRA)

SAIL	AREA m ²
Total	137.80 m ²
Mainsail	52.40 m ²
Genoa (Maxi)	85.40 m ²

I	18.89 m
J	6.05 m
P	16.70 m
E	5.40 m

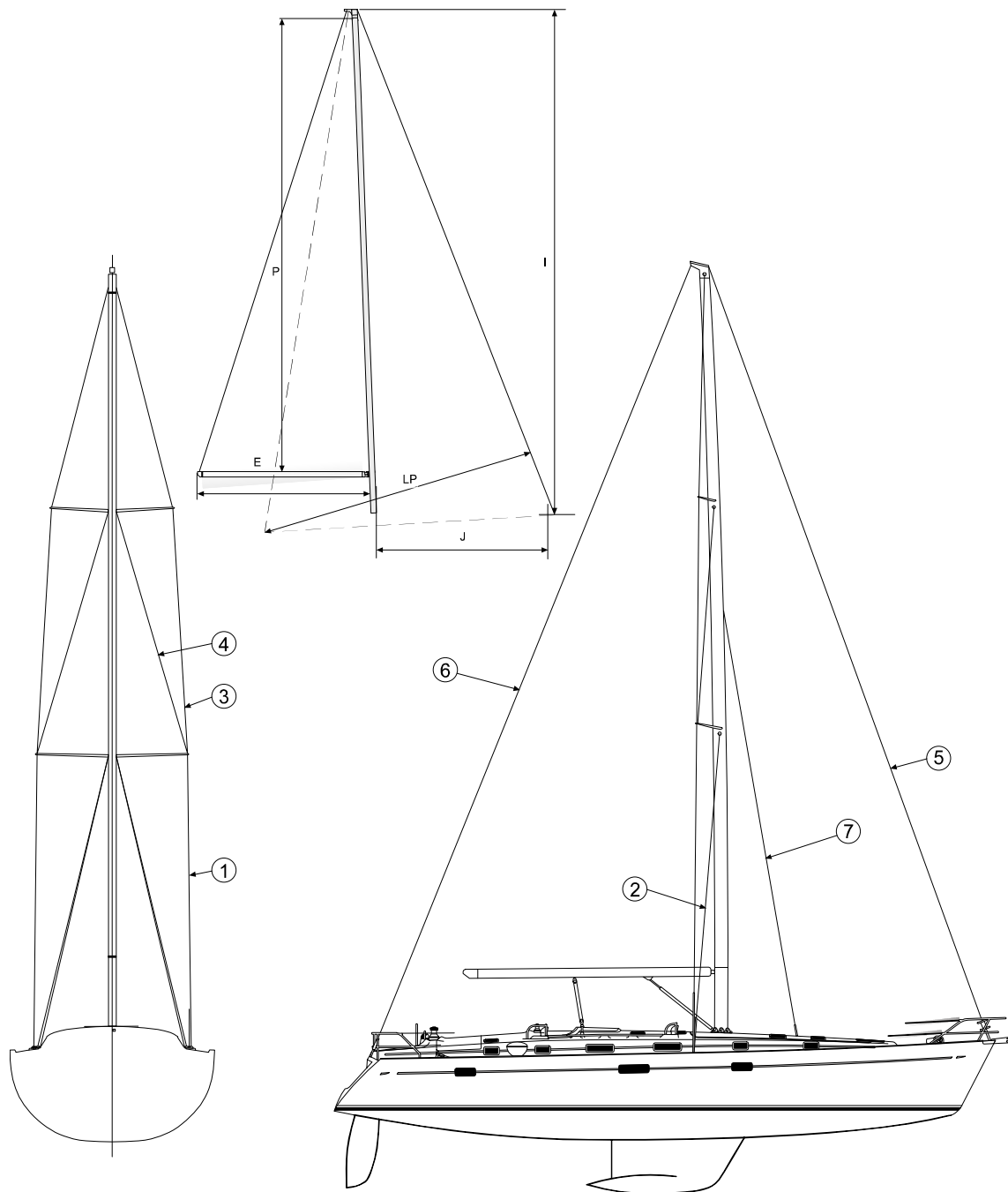

DECK FITTING LAY OUT FOR STANDARD MAST

REF	DESCRIPTION
1	Mainsail Sheet
2	Genoa Furling Line
3	Mainsail Halyard
4	Reef n° 1
5	Reef n° 2
6	Extra Jam Cleat if 2 nd Genoa Halyard as an Optional Extra
7	Spinnaker Boom Topping Lift /Removable Forestay (Optional Extra)
8	Spinnaker Halyard on Starboard
9	Spinnaker Boom Downhaul (Optional Extra)
10	Boom Downhaul Line

Genoa Halyard on the Mast on Portside

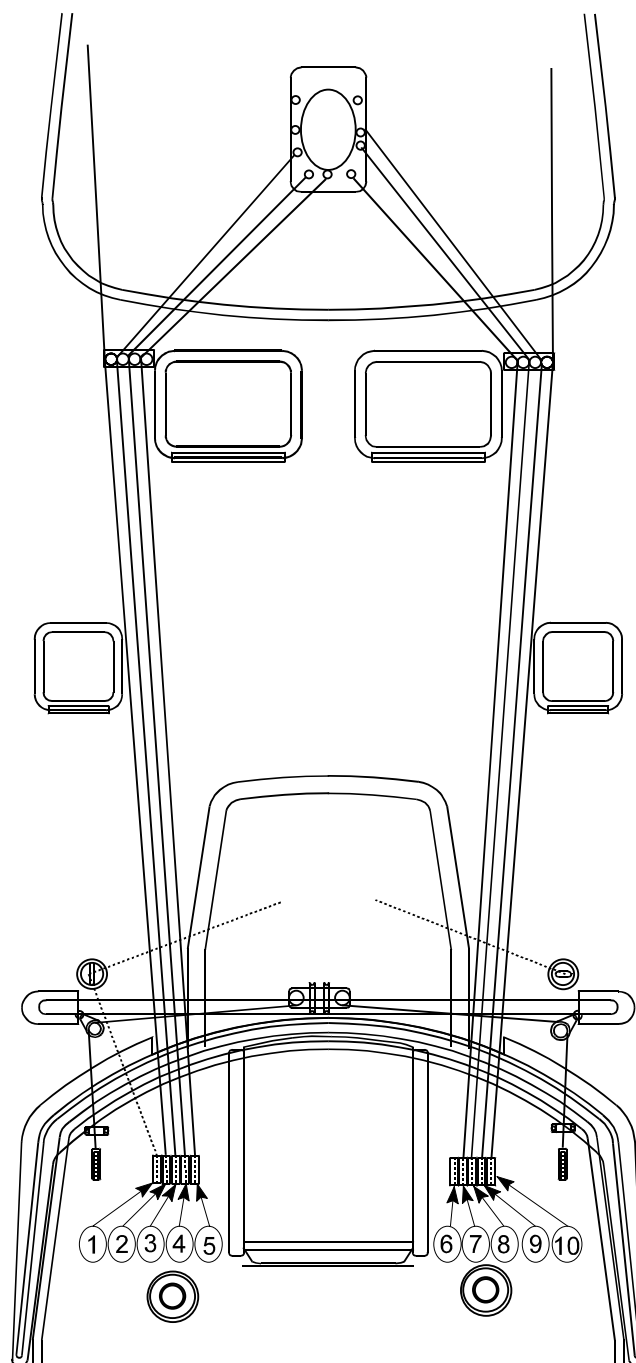

DECK FITTING LAY OUT FOR IN MAST FURLER (OPTIONAL EXTRA)

REP	DESCRIPTION
1	Mainsail Sheet
2	Genoa Furling Line
3	Mainsail Halyard
4	Mainsail Furling Line
5	Mainsail Unfurling Line
6	Extra Jam Cleat if 2 nd Genoa Halyard as an Optional Extra
7	Spinnaker Boom Topping Lift / Removable Forestay (Optional Extra)
8	Spinnaker Halyard on Starboard
9	Spinnaker Boom Downhaul (Optional Extra)
10	Boom Downhaul Line

Genoa Halyard on the Mast on Portside

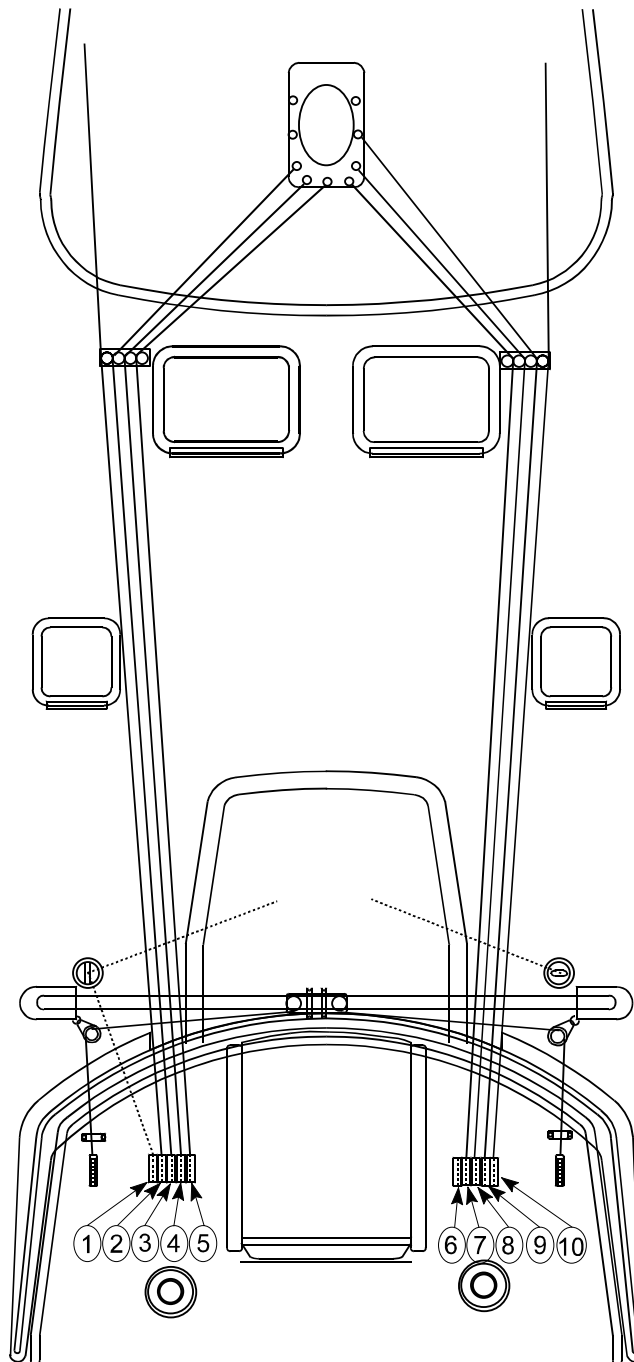



DECK FITTING LAY OUT FOR SPORT MAST (OPTIONAL EXTRA)

REF	DESCRIPTION
1	Mainsail Sheet
2	Genoa Furling Line
3	Mainsail Halyard
4	Genoa Halyard on the Mast as Standard
5	Reef n° 1
6	Reef n° 2
7	Reef n° 3 if necessary (Optional Extra)
8	Boom Downhaul Line
9	Spinnaker Boom Topping Lift / Removable Forestay (Optional Extra)
10	Spinnaker Halyard on Starboard
11	Spinnaker Boom Downhaul (Optional Extra)
12	Mainsail Foot Tuning Line (As Standard under the Boom)
13	Extra Jam Cleat if 2 nd Genoa Halyard as an Optional Extra

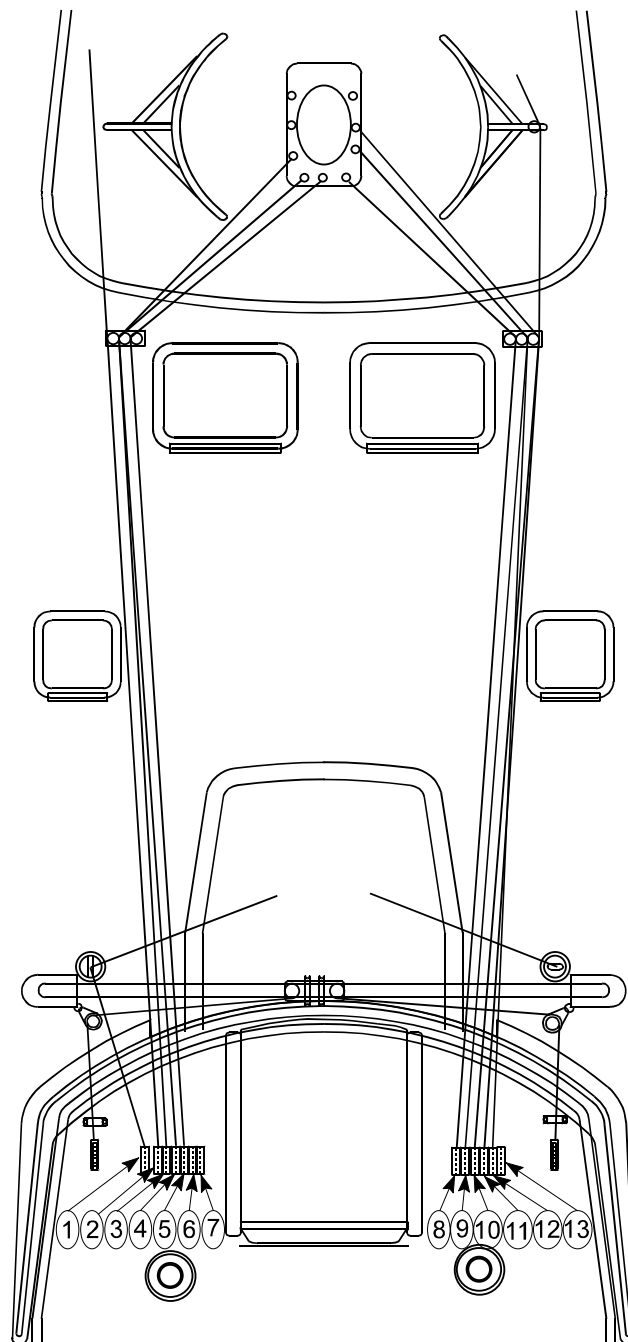
Genoa Halyard on the Mast on Portside

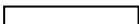

AUTOMATIC FURLING LINE CIRCUIT – STANDARD MAST

-  Reef n° 1
-  Reef n° 2

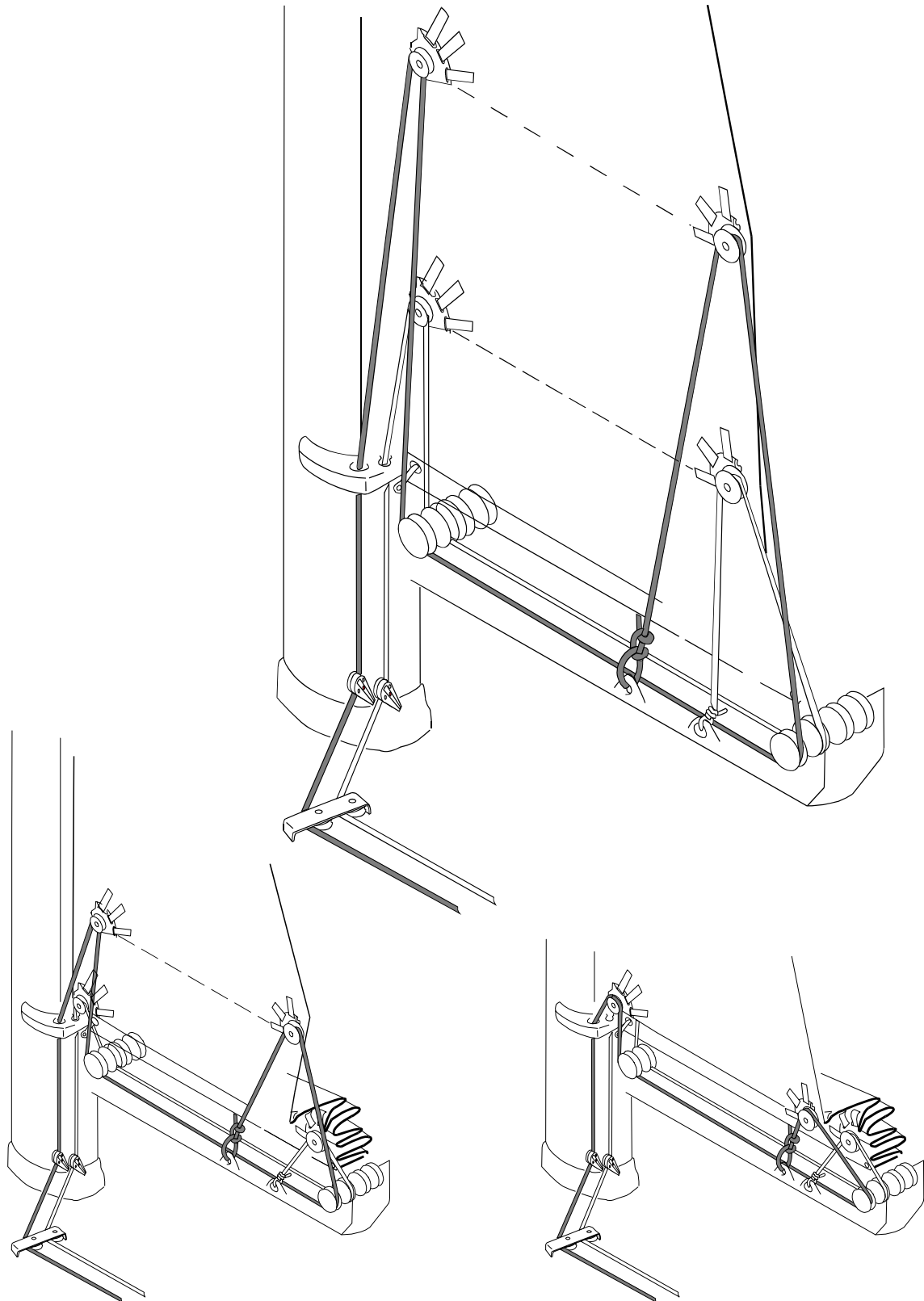

MAINSAIL TACKLE

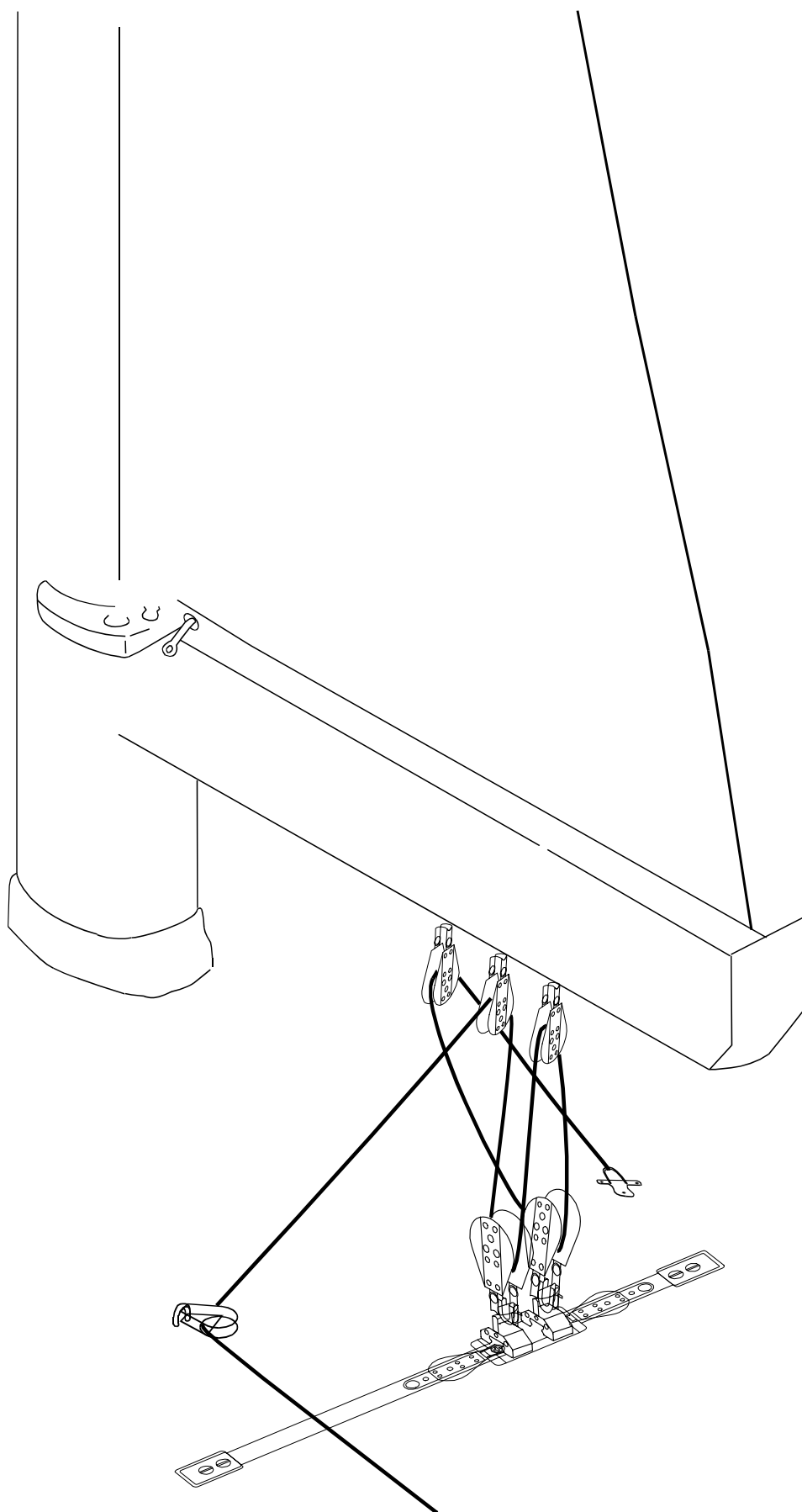

VI) FRESH WATER SYSTEM

REF	DESCRIPTION
1	Water Tank -170 l
2	Water Tank -170 l
3	Water Tank -220 l
4	Filler – Fresh Water Tank
5	Vent Hole – Fresh Water Tank
6	Collector Fresh Water System with Water Seacocks
7	Filter – Fresh Water System
8	Water Pump
9	Surge Tank – Fresh Water
10	Boiler (capacity : 42 l)
11	Outlet Pump of the Shower
12	Filter on Shower Outlet
13	Galley Sink
14	Washbasin/Shower
15	Icebox – capacity : 200 l in Chart Table on Starboard Version
16	Icebox – capacity : 300 l in Chart Table on Portside Version
17	Foot Pump – Fresh Water for Galley Sink
18	Foot Pump –Icebox Outlet
19	Cockpit Shower
20	Water Tank – 390 l
21	Filter on Foot Pump – Galley Sink

The fresh water system supplies the sink in the galley and the washbasins. This supply is made depending on the models, either by a manual pump , or by an electric pump; before this pump there is a filter it is necessary to clean regularly.

Never run an electric pump when the tank is empty otherwise it might be irreparably damaged.

Never force the filling nozzle deep down the filler pipe in order to prevent any over pressure in the systems and keep an eye on the vent hole(s) through which the water in excess will be discharged.

When the system has not been used for a long period of time, the tanks and pipes shall be cleansed with an acetic acid solution (white vinegar)

The water flows out from the sink and wash basins through their own skin fitting seacocks ; Close them when the water system is not used.

LAY OUT OF THE FRESH WATER SYSTEM

3 CABIN AND 4 CABIN VERSIONS

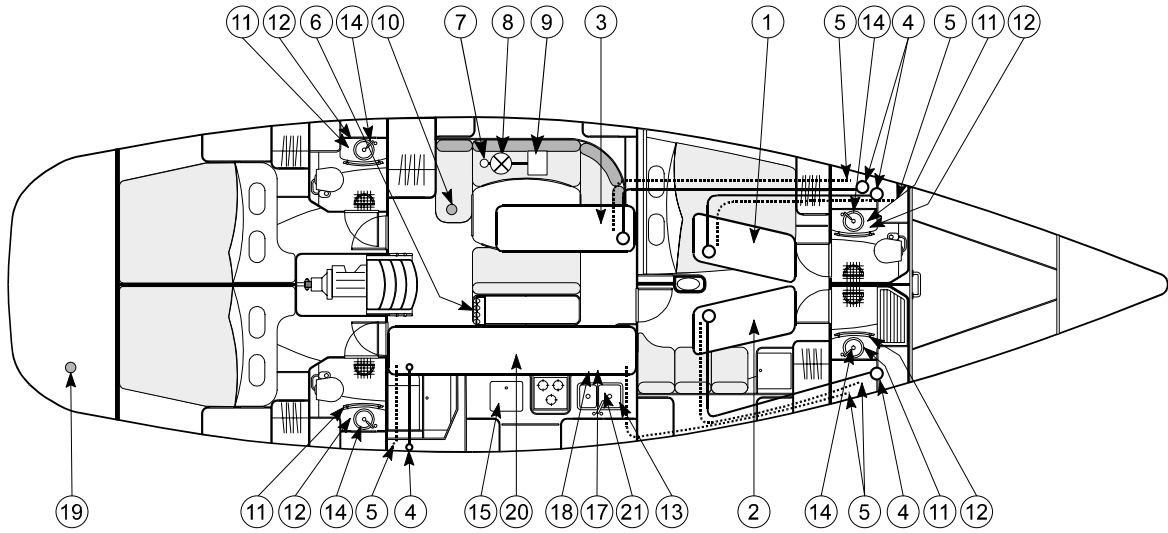

2 AFT CABIN – 1 CENTRAL FORWARD BERTH VERSION

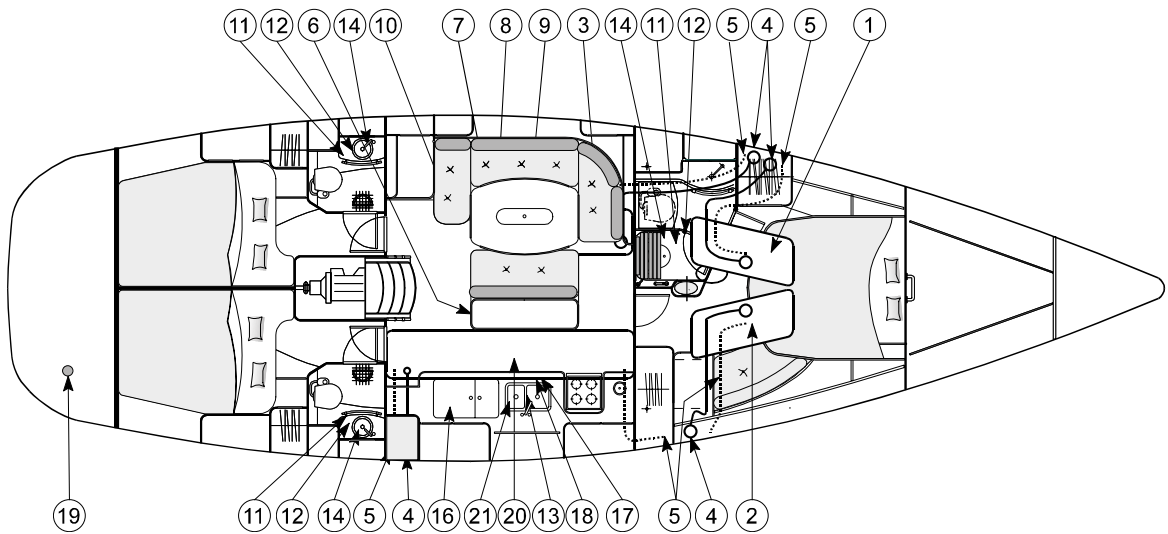

VII) BILGE PUMP SYSTEM

REF	DESCRIPTION
1	Electric Bilge Pump 17 l/mn
2	Filter of the Electric Bilge Pump
3	Sump
4	Manual Bilge Pump 2 l /each time
5	Electric Bilge Pump Intake
6	Manual Bilge Pump Intake
7	Electric Bilge Pump Delivery
8	Manual Bilge Pump Delivery
9	Automatic Electric Bilge Pump 110 l/mn
10	Automatic Electric Bilge Pump Delivery

Make sure the bilge pump system is in good working order before you put out to sea.

Make yourself acquainted with the way the bilge pump system of your boat works :

- **Locate the manual bilge pump and the handle which enables you to make it work.**
- **Locate the on switch of the electric bilge pump and get to know how the seacocks work**

(for the boats fitted with an electric bilge pump).

(See the lay out drawing of the system in the owner's handbook)

Make sure that the bilge pump intake strum box is not blocked with dirt.

Regularly clean the intake strum box on the sump and the filter of the system in case of an electric pump.

LAY OUT OF THE BILGE PUMP SYSTEM

ANY OF THE VERSIONS

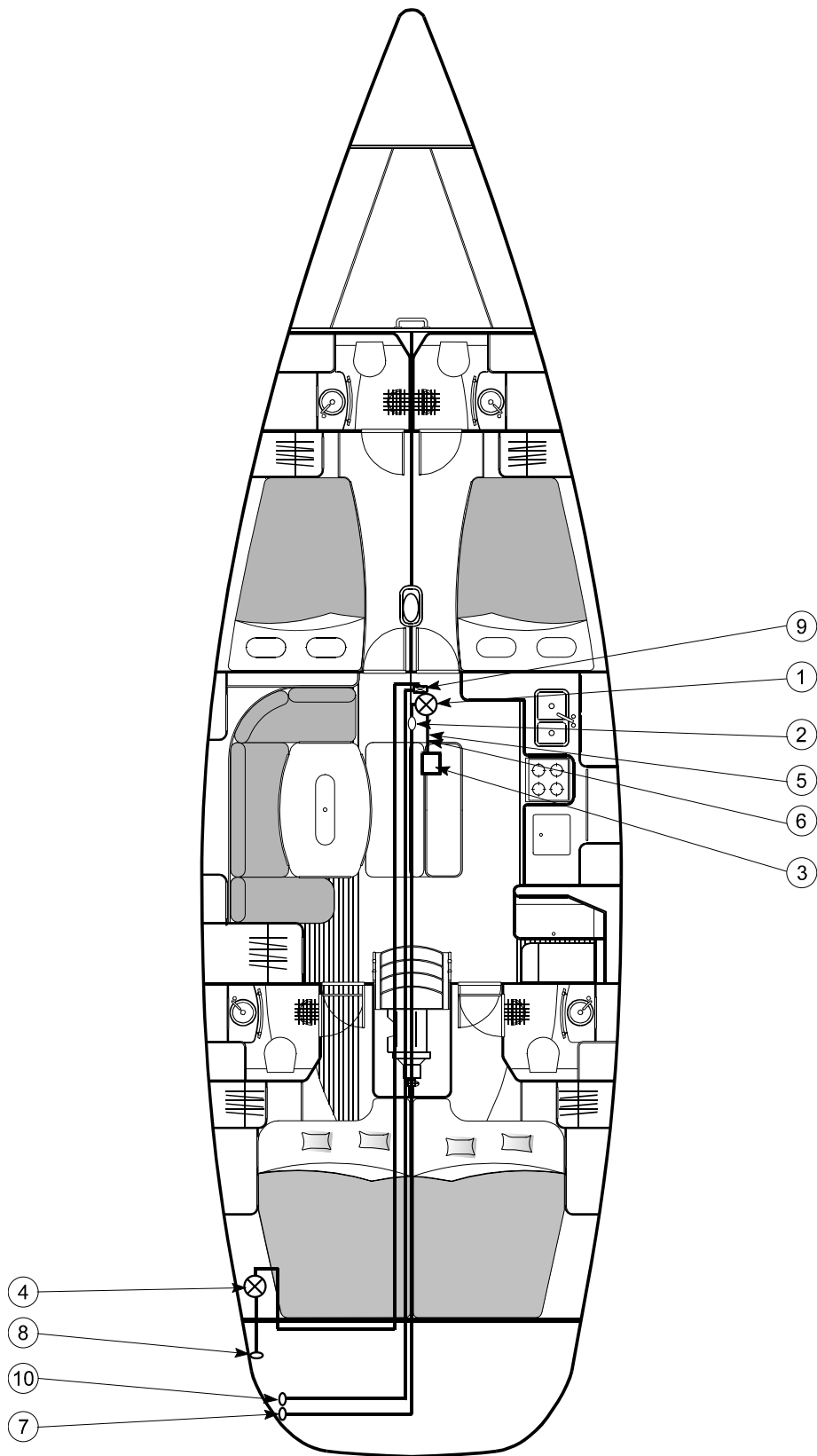

VIII) SEACOCKS AND SKIN FITTINGS

Close all the seacocks when you leave the boat.

The flushing toilets may be situated below the waterline ; get into the habit of systematically closing the seacocks after each use.

Make sure that all the seacocks which are not used are closed before you put out to sea. (in the owner's manual, see the drawing where the lay out of the skin fittings is shown).

Opening and closing of the seacocks

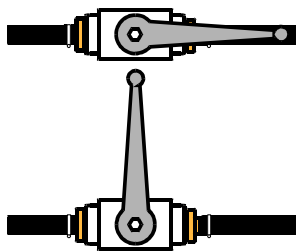

Open

Closed

REF	DESCRIPTION
1	Heads Outlet
2	Heads Intake
3	Washbasin / Shower Outlet
4	Washbasin Outlet
5	Sink / Icebox Outlet
6	Engine Cooling Water Intake (Volvo Version)
8	Stern Tube Skin Fitting (Volvo Version)
9	Log / Sounder Skin Fitting
10	Cockpit Shower
11	Seacock to Select Water Tank
12	Engine Cooling Water Intake (Yanmar Version)
13	Stern Tube Skin Fitting (Yanmar Version)

SEACOCK AND SKIN FITTING LAY OUT

3 CABIN AND 4 CABIN VERSIONS

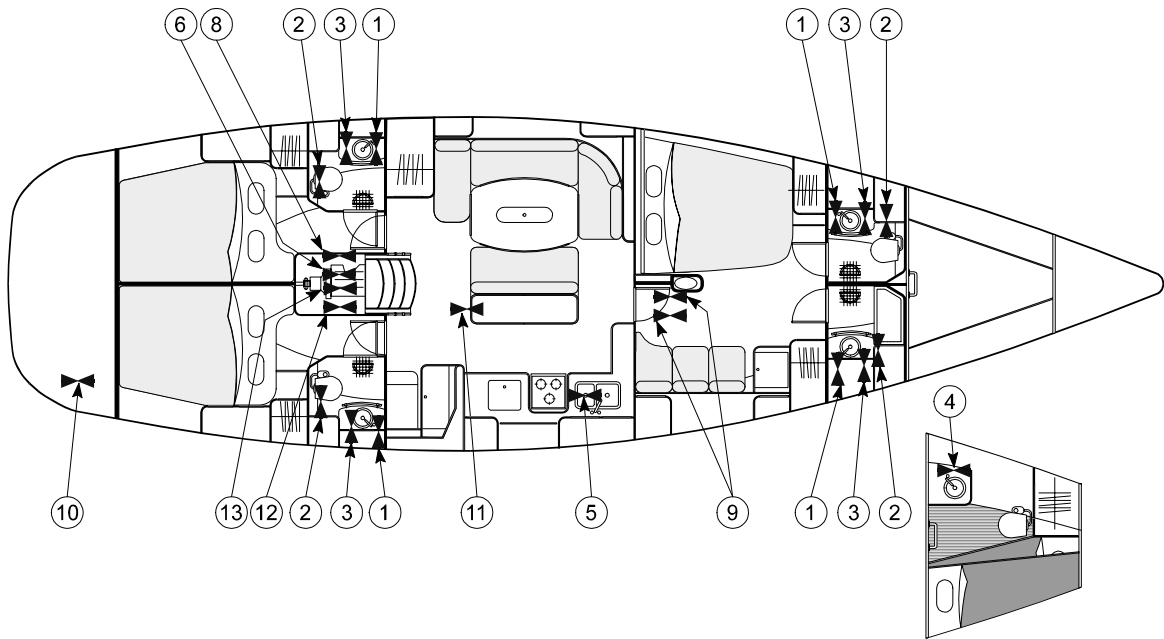

2 AFT CABIN – 1 CENTRAL FORWARD BERTH VERSION

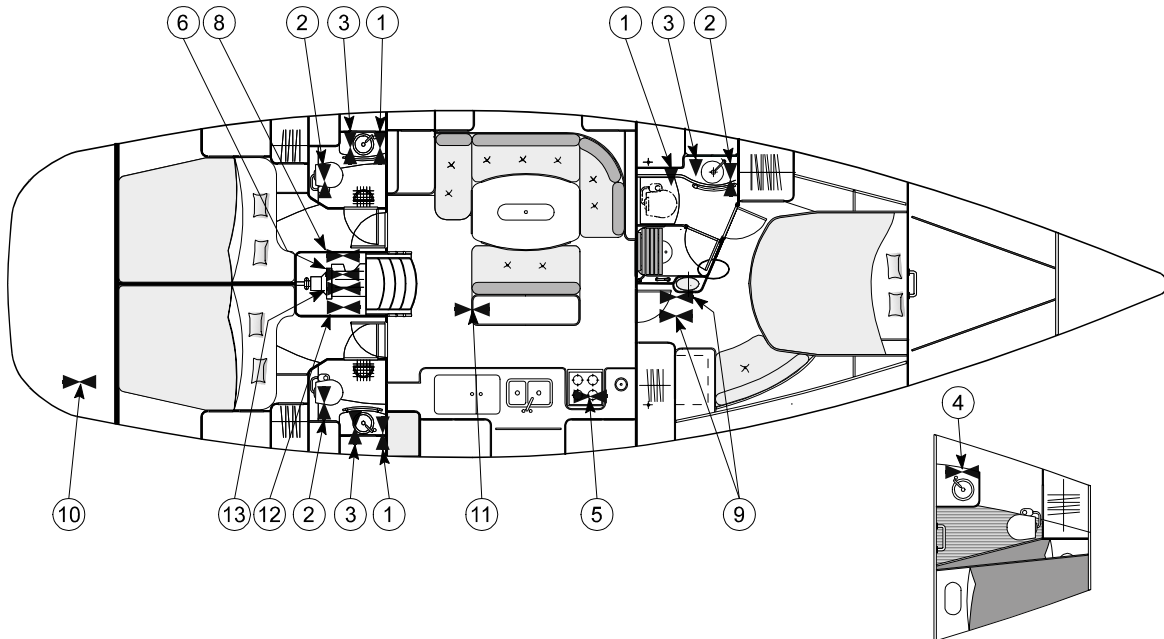

IX) ELECTRIC SYSTEMS

When the voltage is not specified, all the functions or panels are in 12 Volts.

12V Electric System

Never work on a live electric fitting.

Never tamper with an electric fitting. Call in a technician qualified in marine electricity.

The batteries must be carefully and safely stowed.

In order to prevent a short circuit between the battery terminals, do not store conductive objects near the batteries (e.g. metal tools, ...)

Never alter the specifications of the devices which protect against overstrength.

Never fit or replace the electric materials or appliances by components which exceed the system amperage.

110V-220V Electric System

Some boats are fitted with a 110V or a 220 V system (some as standard, others as an option, depending on the models). We advise you to follow the below mentioned steps in order to avoid the risks of electric shocks and of fire.

Do not work on a live fitting.

Connect the boat / shore supply cable in the boat before you plug it into the shore supply socket itself.

Do not immerse the boat / shore cable sockets.

Switch off the shore supply with the switch on board before you plug in or unplug the boat / shore supply cable.

Do not tamper with the connections of the Boat / shore supply cable. Use only compatible connections.

ELECTRICITY LAY OUT

12V and 110/220V Electric Panel

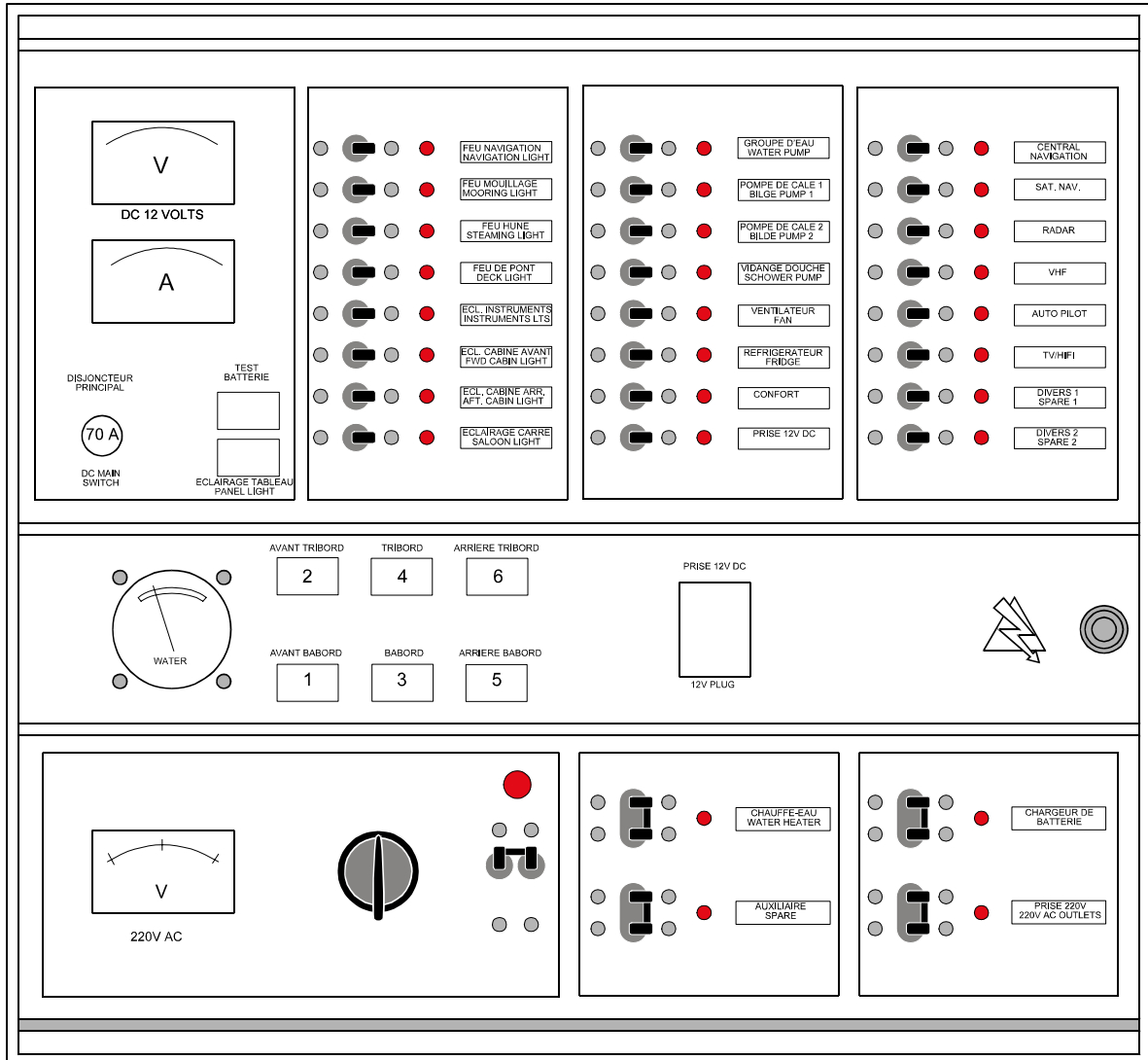

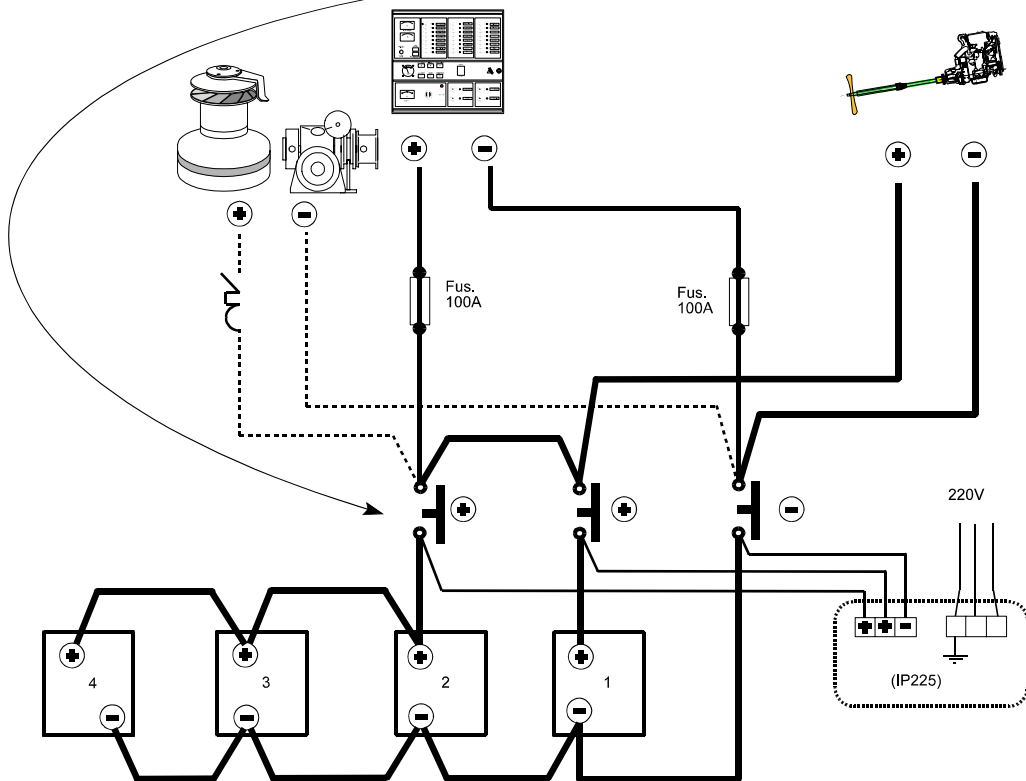
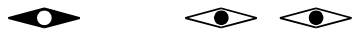
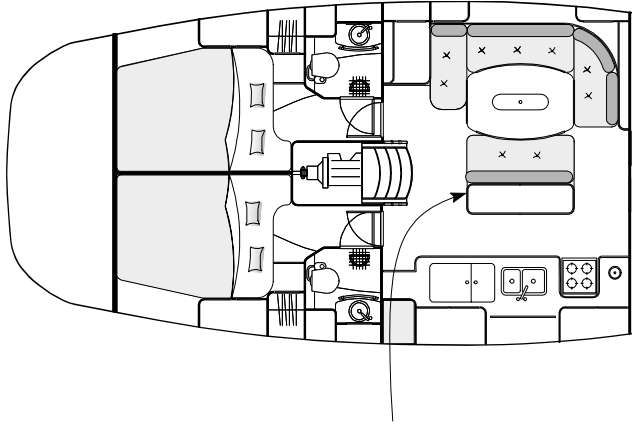

LAY OUT OF THE 12V LIGHTS AND APPLIANCES

REF	DESCRIPTION	FUNCTION ON PANEL
1	Bicolour Bow Navigation Light	Navigation Lights
10	White Stern Navigation Light	Navigation Lights
5	Mooring Light	Mooring Light
6	Steaming Light	Steaming Light
7	Deck Light	Deck Light
91	Compass Light	Instrument Lights
92	Compass Light	Instrument Lights
93	Cockpit Table Light	Instrument Lights
31	Reading Light	Forward Cabin Lights
32	Reading Light	Forward Cabin Lights
33	Reading Light	Forward Cabin Lights
34	Ceiling Light	Forward Cabin Lights
35	Ceiling Light	Forward Cabin Lights
36	Ceiling Light	Forward Cabin Lights
37	Ceiling Light	Forward Cabin Lights
38	Ceiling Light	Forward Cabin Lights
39	Ceiling Light	Forward Cabin Lights
40	Ceiling Light	Forward Cabin Lights
41	Ceiling Light	Forward Cabin Lights
42	Ceiling Light	Forward Cabin Lights
43	Ceiling Light	Forward Cabin Lights
45	Ceiling Light	Forward Cabin Lights
47	Ceiling Light	Forward Cabin Lights
61	Ceiling Light	Forward Cabin Lights
62	Ceiling Light	Forward Cabin Lights
63	Neon Tube	Forward Cabin Lights
70	Ceiling Light	Aft Cabin Lights
71	Ceiling Light	Aft Cabin Lights
72	Ceiling Light	Aft Cabin Lights
73	Ceiling Light	Aft Cabin Lights
74	Ceiling Light	Aft Cabin Lights
75	Ceiling Light	Aft Cabin Lights
76	Ceiling Light	Aft Cabin Lights
77	Ceiling Light	Aft Cabin Lights
78	Ceiling Light	Aft Cabin Lights
79	Ceiling Light	Aft Cabin Lights
80	Ceiling Light	Aft Cabin Lights
81	Ceiling Light	Aft Cabin Lights
50	Red Ceiling Light	Saloon Lights
51	Orange Night Light	Saloon Lights
52	Ceiling Light	Saloon Lights
53	Ceiling Light	Saloon Lights
54	Ceiling Light	Saloon Lights
56	Fluorescent Ceiling Light	Saloon Lights
57	Ceiling Light	Saloon Lights
58	Ceiling Light	Saloon Lights
59	Ceiling Light	Saloon Lights
13	Water Pump	Water Pump
141	Bilge Pump 1	Bilge Pump 1
142	Bilge Pump 2	Bilge Pump 2
161	Shower Outlet Pump	Shower Outlet
162	Shower Outlet Pump	Shower Outlet
163	Shower Outlet Pump	Shower Outlet
163	Shower Outlet Pump	Shower Outlet

LAY OUT OF THE 12 V LIGHTS AND APPLIANCES

REF	DESCRIPTION	FUNCTION ON PANEL
19	Ventilator (Optional Extra)	Ventilator
11	Fridge	Fridge
27	Radio and Cassette Player	TV / HIFI
21	Water Tank Gauge	Forward – Portside 1
22	Water Tank Gauge	Forward – Starboard 2
23	Water Tank Gauge	Portside
24	Water Tank Gauge	Starboard
Tab	12 V Electric Panel	

12V FUNCTIONS

REF	FUNCTION	AMPERAGE (A)
A	Navigation Light	10
B	Mooring Light	5
C	Steaming Light	5
D	Deck Light	10
E	Instrument Lights	5
F	Forward Cabin Lights	10
G	Aft Cabin Lights	10
H	Saloon Lights	16
I	Water Pump	10
J	Bilge Pump 1	10
K	Bilge Pump 2	10
L	Shower Outlet	20
M	Ventilator	10
N	Fridge	10
O	Comfort	16
P	12 V DC Socket	10
Q	Navigation Instruments	10
R	Sat-Nav	10
S	Radar	10
T	VHF	10
U	Auto Pilot Gear	10
V	TV / HIFI	16
W	Spare 1	10
X	Spare 2	16

110/220V FUNCTIONS

REF	FUNCTION	AMPERAGE (220) (Amp)	AMPERAGE (110) (Amp)
A0	General Power Supply	70	70
A1	Boiler	10	16
A2	Auxiliary Power	20	20
A3	Battery Charger	10	16
A4	Socket	16	20

12V LIGHT AND APPLIANCE LAY OUT

2 AFT CABIN – 1 CENTRAL FORWARD BERTH VERSION
 CHART TABLE ON STARBOARD

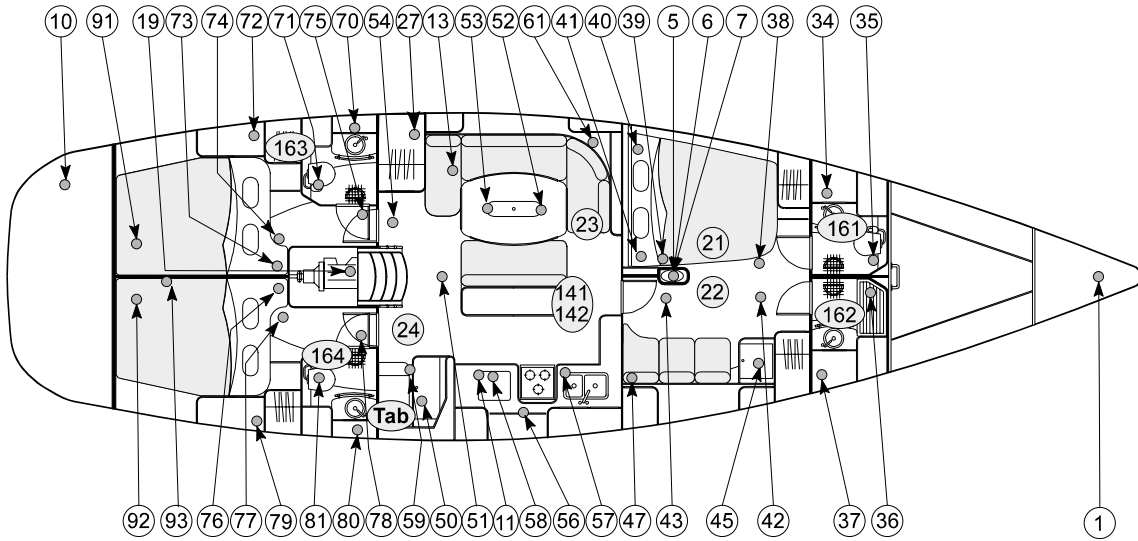

SKIPPER'S CABIN (OPTIONAL EXTRA)

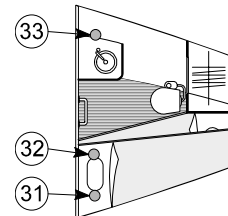

2 AFT CABIN – 1 CENTRAL FORWARD BERTH VERSION
 CHART TABLE ON PORTSIDE

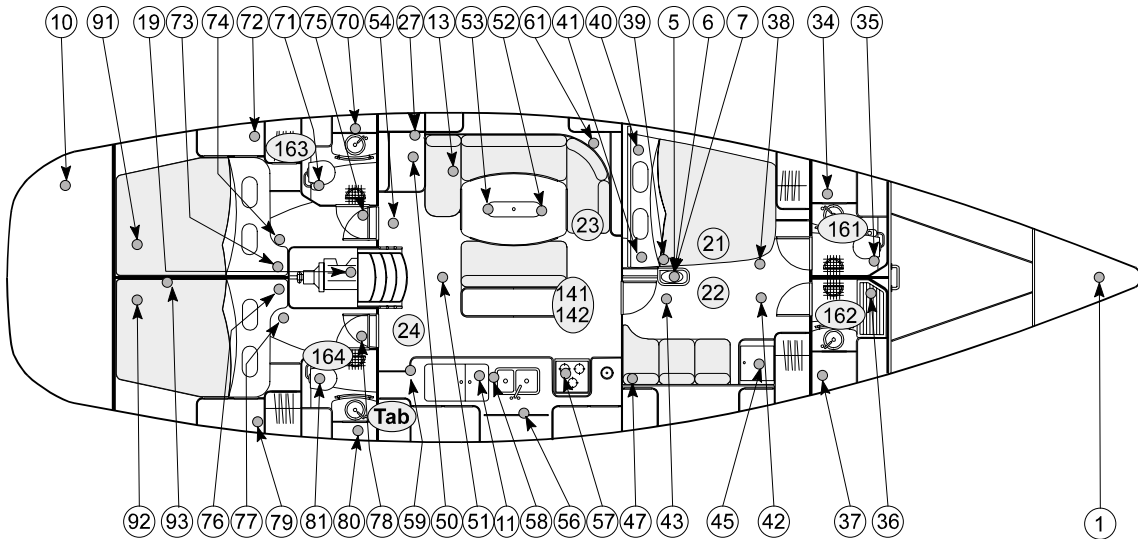

SKIPPER'S CABIN (OPTIONAL EXTRA)

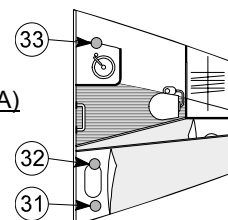

3 CABIN AND 4 CABIN VERSION (CHART TABLE ON STARBOARD)

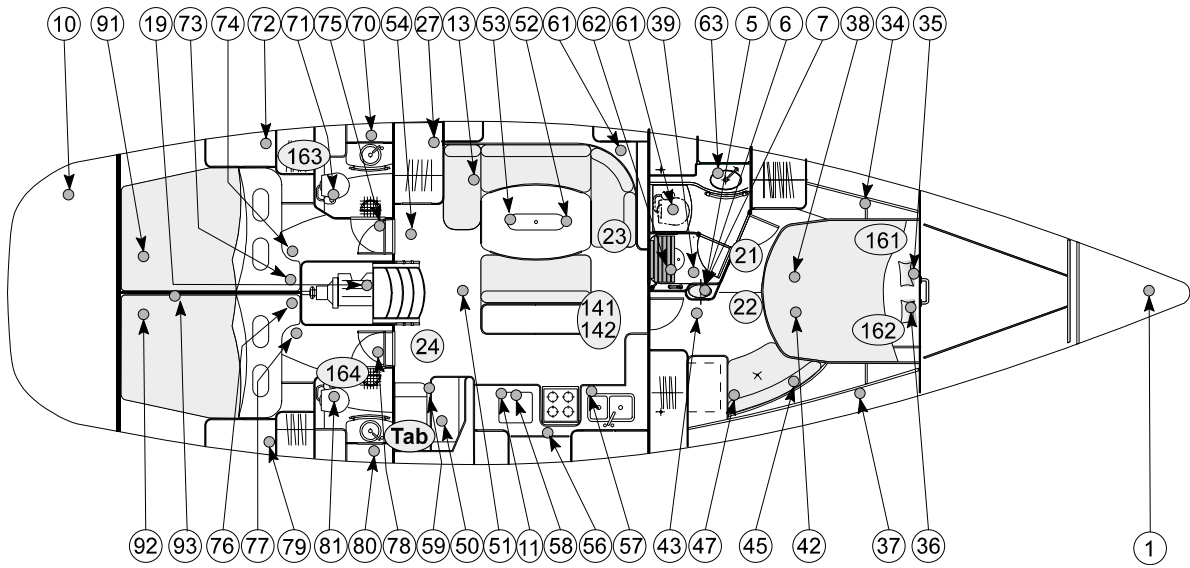

SKIPPER'S CABIN (OPTIONAL EXTRA)

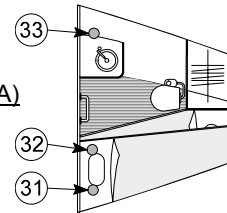

3 CABIN AND 4 CABIN VERSION (CHART TABLE ON PORTSIDE)

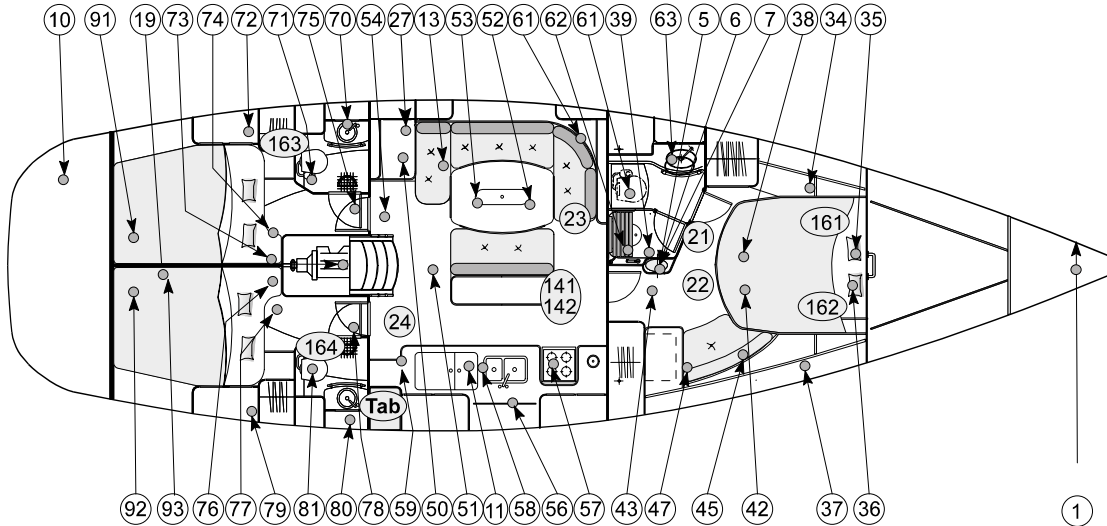

SKIPPER'S CABIN (OPTIONAL EXTRA)

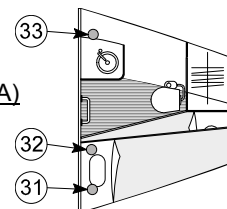

LOCATION OF THE 110 / 220V FUNCTIONS

REF	DESCRIPTION
1	Shore Supply Socket
2	Battery Charger
3	110/220V Socket
4	Boiler
5	Switch
6	Circuit Breaker

CHART TABLE ON STARBOARD VERSIONS

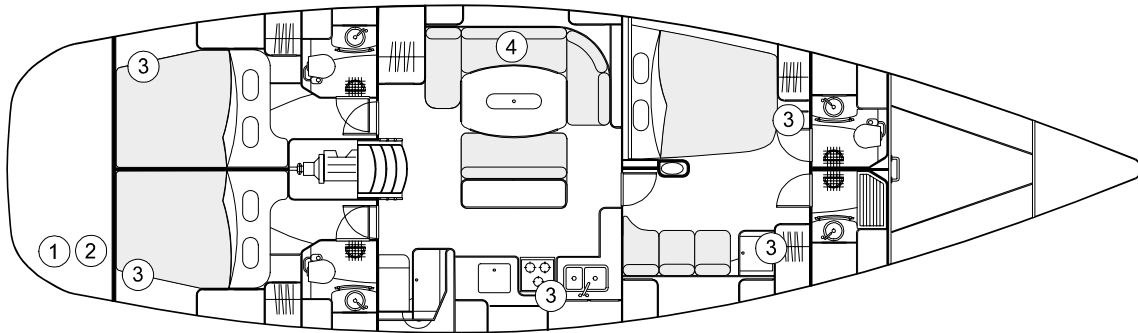

SKIPPER'S CABIN (OPTIONAL EXTRA)

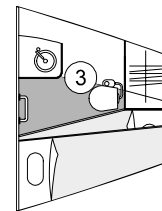
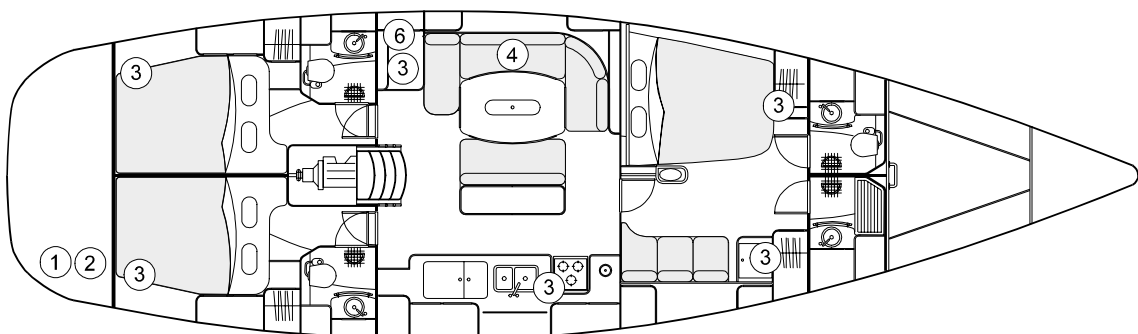

CHART TABLE ON PORTSIDE VERSIONS



LAY OUT OF THE OPTIONAL EXTRA SHEATHES

REF	DESCRIPTION
1	Sheath from Panel to 220 V Socket
2	Sheath from Panel to Auto Pilot Gear
4	Sheath from Panel to Mast Foot
5	Sheath from Panel to Log / Sounder
6	Sheath from Windlass to Relay Box

CHART TABLE ON STARBOARD VERSIONS

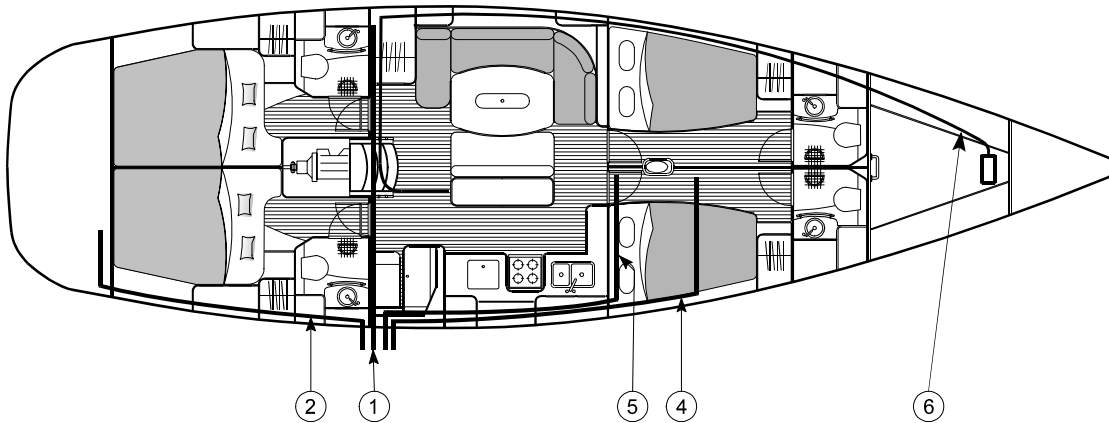
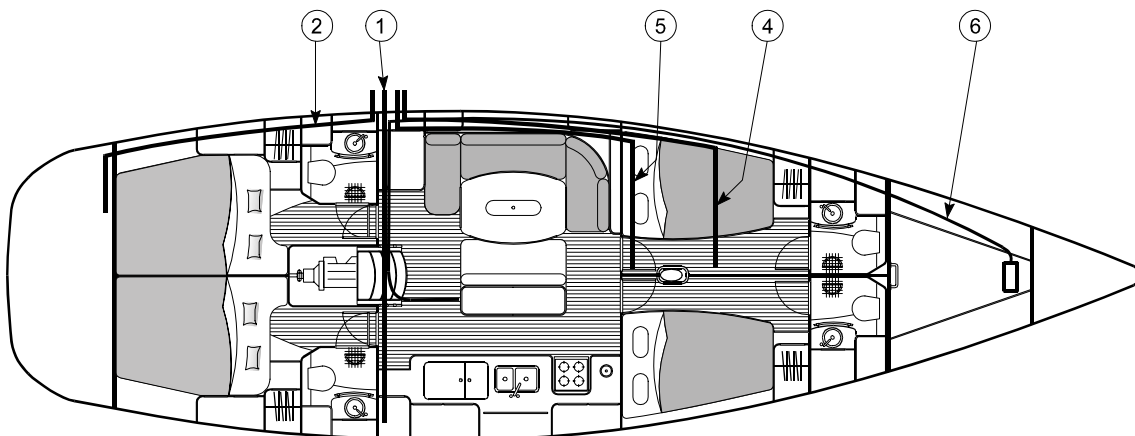

CHART TABLE ON PORTSIDE VERSIONS



X) GAS SYSTEMGas Stove

The boat is delivered without any fire extinguisher. It is your own responsibility to comply with the laws and regulations of your own country (Number, capacity, type and place of fire extinguishers). We advise you at least to install an extinguisher less than 5 metres away from each berth, less than 2 meters away from the extinguisher aperture in the engine compartment, less than 2 meters away from any naked flame device and less than 1 meter away from the helm pedestal. We advise a total capacity of the portable extinguishers reaching 8A/64B, each extinguisher having at least a 5A/34B capacity. The CO2 extinguishers shall be used to fight fires in the galley or electric fires.

Do not fit or store flammable materials above or over the stove (Curtains, papers, napkins, and so on.....).

Never leave the boat unattended when the gas or spirit appliances are working.

The appliances which use fuel consume the oxygen within the cabin and release the combustion products into the boat. It is necessary to ventilate the boat when the gas cooking appliances are working. Do not obstruct the air vents of the boat.

Do not smoke or use a naked flame when you are trying to locate a gas leak or when you change the gas bottle or whenever you intervene on the gas system.

If you smell gas or find that the burners have gone out, by accident, (although appliance models cut off the gas automatically if the flames go out) turn off the gas taps and do ventilate the boat in order to get rid of any residual gas. Find the root of the problem.

For the stoves with an integral gas cylinder you shall change the cylinder outside the boat. Test the stove before you put it back in the galley. Pay particular attention to the stove fittings and make sure the stoves are locked after they have been put in their places.

Do not use cooking appliances to heat the inside of the boat.

Make sure that the taps of the burners are turned off before you turn on the tap of the hoses and of the cylinder.

Turn off the tap on the feed hose and the taps on the cylinders when you do not use the appliances.

Do not obstruct the access to the gas system components, in particular the access to the taps (cylinders and gas cooker).

The flexible hoses which connect the gas cylinder at one end of the system and the stove at the other end, shall be changed in pursuance of the regulations in force in your country. Only use hoses which meet the safety standards of your country.

Do not use the gas cylinder storage space to store other equipments.

Pay particular attention to keep in good condition the screw thread of the cylinder on which the regulator is. Check the condition of the regulator every year and change it if necessary. Use a regulator identical to the ones which are fitted.

Make sure that the taps of the empty cylinders are turned off and disconnected from the system.

Do not use ammonia based products to clean it or to discover a leak.

Spirit Stove

Some boats are fitted with a spirit stove.

Do not smoke when handling the fuel.

Keep the fuel in a can for this purpose, a good distance away from the stove, the engine and any other sources of heat.

Follow the manufacturer's recommendations as far as the filling of the burners is concerned. Do not pour the spirit directly into the burner over the stove.

Only use methylated spirits. Petrol, oil, propane, diesel oil, fuel oil or other fuels and flammable materials are to be proscribed.

Any fuel overflow out of the burner tank shall be wiped up immediately.

LAY OUT OF THE GAS SYSTEM

REF	DESCRIPTION
1	Gas Locker
2	Tap
3	Regulator
4	Gas Locker Ventilation

ANY OF THE VERSIONS

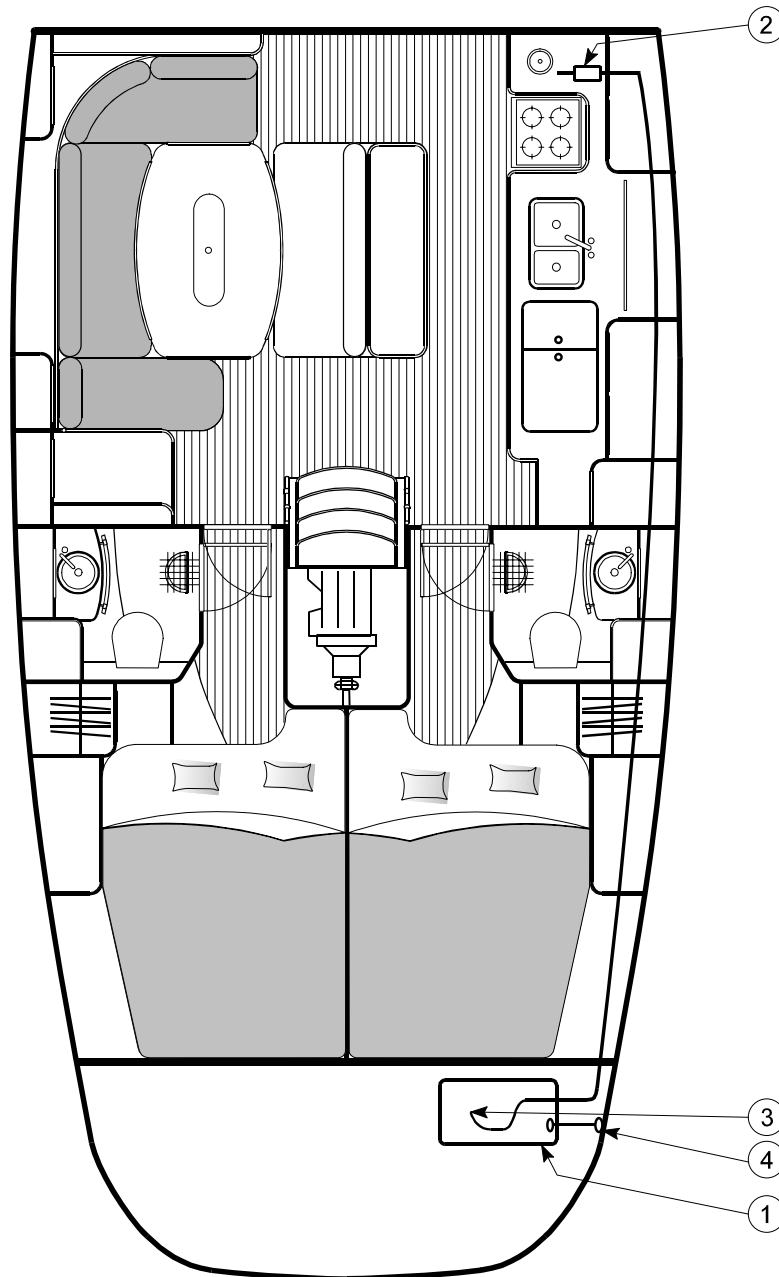

XI) STEERING SYSTEM, EMERGENCY SYSTEM

Boats who are fitted with a steering wheel carry an emergency tiller ; keep clear emergency tiller access.

Check once a year at least that the steering cables are tight properly.

Lift the aft cover, open the cap, drive the emergency tiller into the print on the rudderstock head.

REF	DESCRIPTION
1	Emergency Tiller
2	Cap to Get to the Rudder Stock
3	Rudder Stock
4	Steering Rod
5	Tie Rod
6	Steering Box
7	Upper Bearing
8	Compensation Washer
9	Chain and Steering Cable

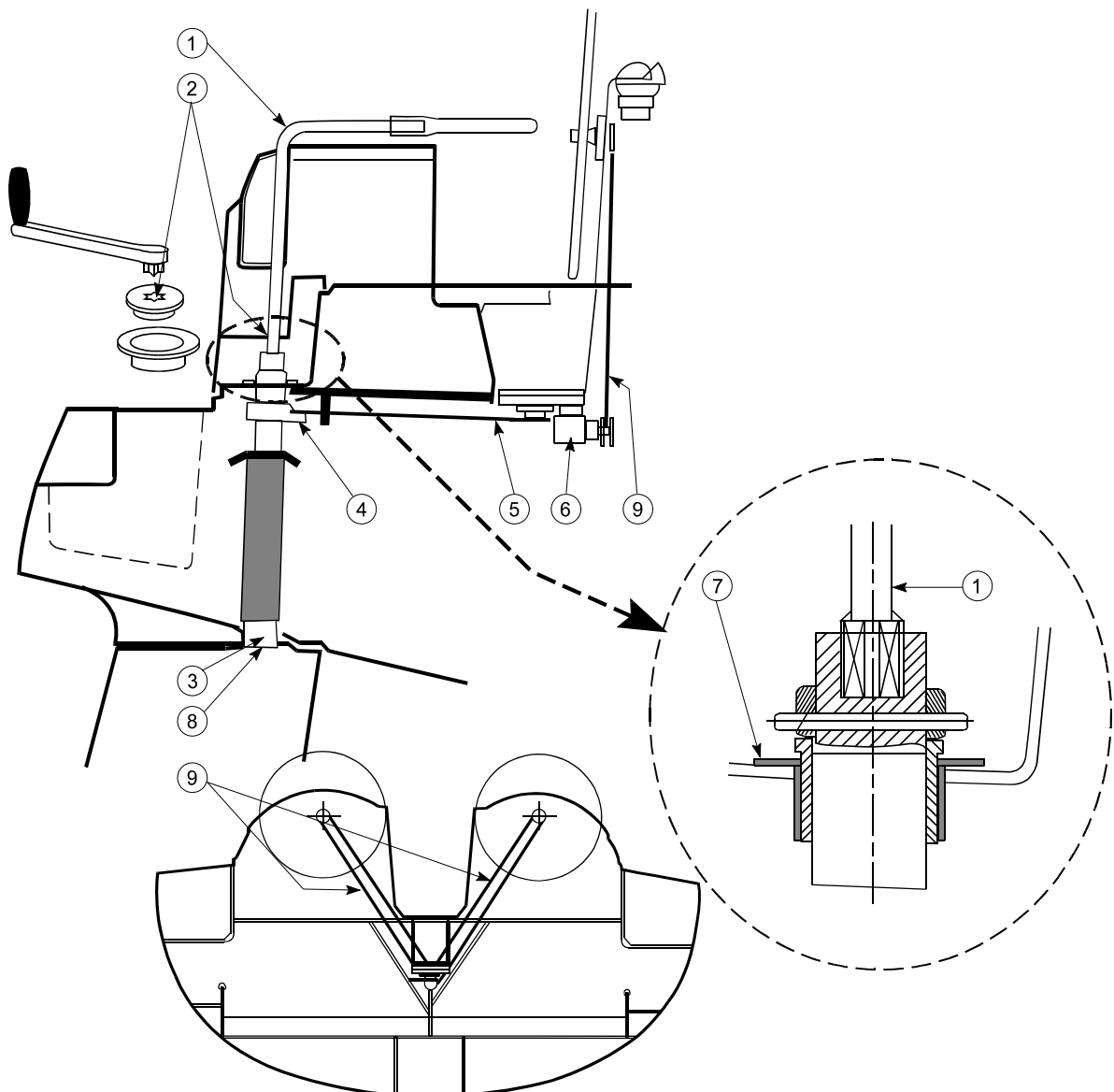

XII) MOTORIZATION

Stop the engine, do not smoke while you are filling up the fuel tank.

Before you start the engine, make sure that the engine compartment bilge is clean and dry. If there is the slightest presence of fuel in the bottom, you must not start the engine.

For the boats fitted with a petrol engine, ventilate the engine compartment for 5 minutes with the bilge ventilators so that the possible petrol vapours may be removed completely.

For the outboard engines with a spare can, fill up the portable tank outside the boat in a well ventilated place and away from any risk of possible fire.

The fuels that are stored outside the tanks (spare cans, jerrycans,...) shall be kept and stored in a ventilated place.

Know exactly where the extinguisher aperture is located so you will be able to put out a fire breaking out in the engine compartment bilge.

A fixed system of extinguisher which enables you to put out a fire breaking out in the engine compartment bilge is fitted in the boats with petrol engines. Know where the release mechanism is and the way it works. It is necessary to ventilate the engine compartment after this mechanism has been released.

REF	DESCRIPTION	REF	DESCRIPTION
1	Engine Ventilation Grid	16	Propeller
2	Engine Air Vent	17	Exhaust Pipe
3	Anti- Siphon	18	Hatch to the Engine
4	GRP Companionway	19	Battery Breaker
5	Extinguisher Aperture	20	Intake Strainer
6	Battery	21	Engine Panel
7	Engine Block	23	Exhaust Outlet
8	Coupling Plate	24	Sea Water Filter
9	Baffle box	25	Decanter Filter
10	Engine Water Intake	26	Engine Stop Control
11	Engine Control Handle in the Cockpit	27	Pull Handle to Stop the Fuel Oil Intake
12	Stuffing Box	28	Fuel Oil Filling Cap
13	Propeller Shaft	29	Stern Tube Valve
14	Tank	30	Tank Vent Hole
15	Stern Tube	31	Bilge Ventilator

ENGINE LAY OUT

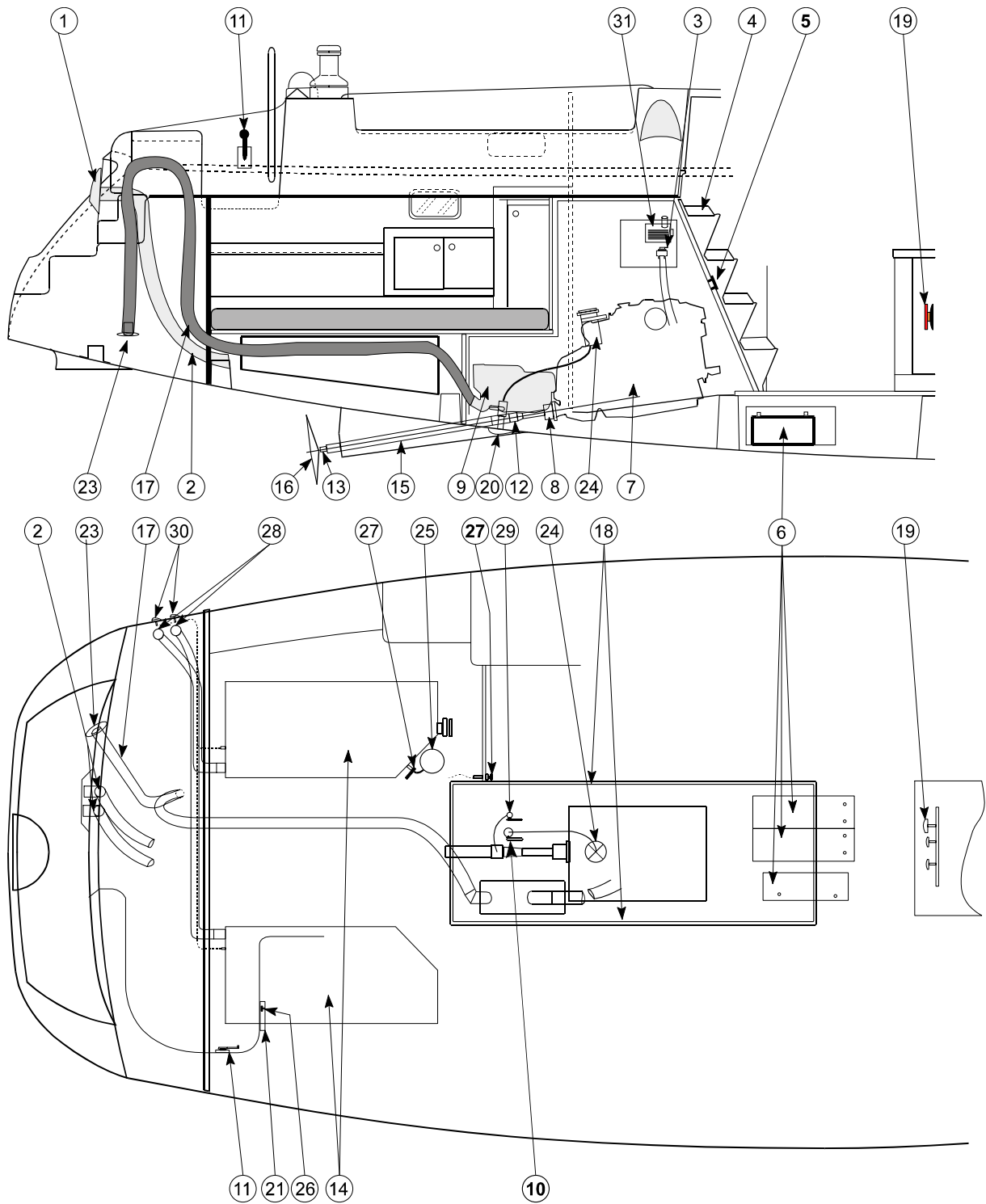

XIII) HANDLING

Contact your BENETEAU dealer for the maintenance and repairs of your boat. He will advise properly, will supply you with the spare parts you need or the materials that are suited to your boat.
Have your boat examined and maintained once a year during the winter storage.

POSITION OF CRANING STRAPS AND CRADLE POSITION.

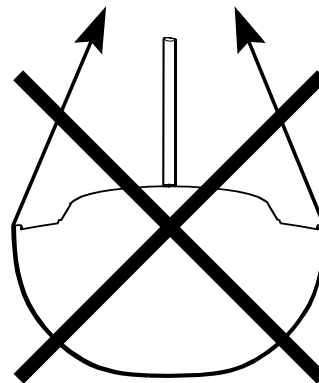
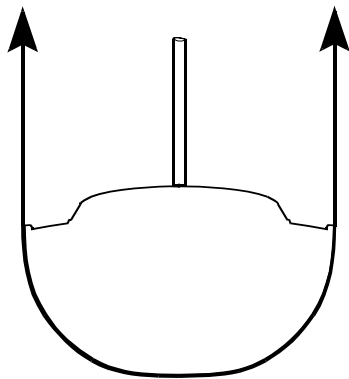
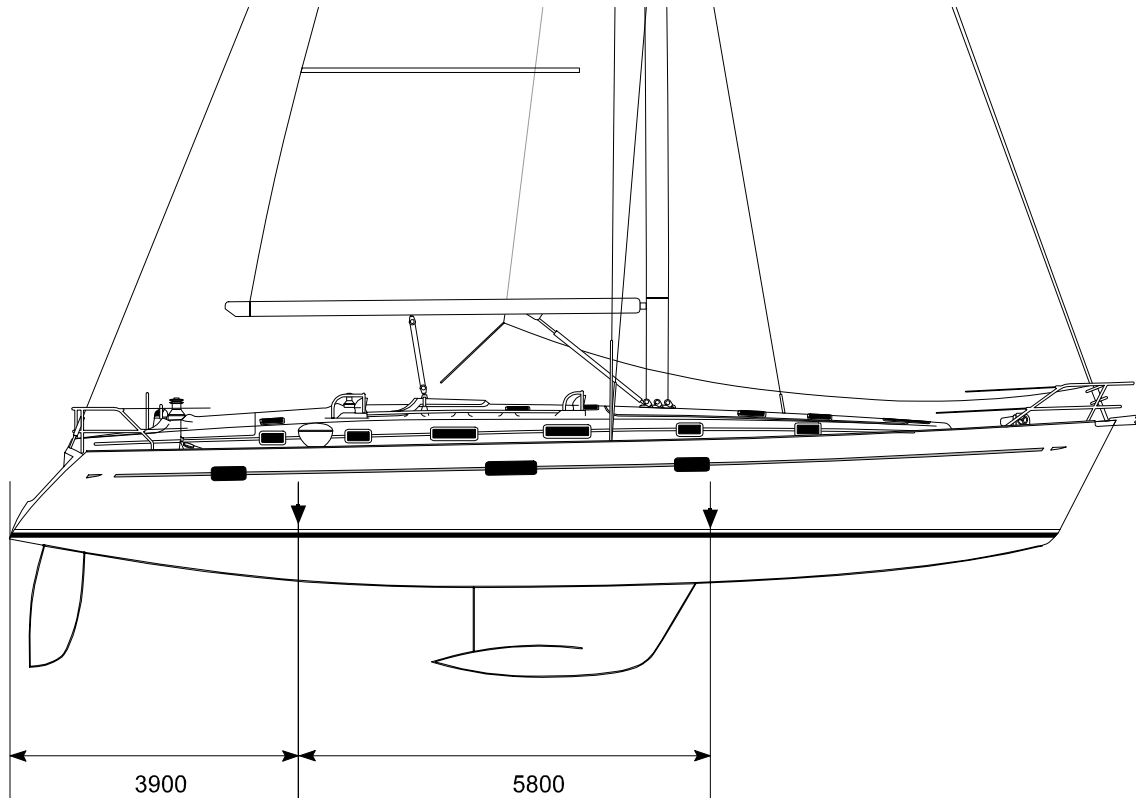

XIV) MAINTENANCE

Because you have chosen to invest your money in a recreational item that spends its life in a harsh environment, it is very important to ensure that your boat is well and regularly maintained. Furthermore, a fair number of accidents are due to negligence and the lack of maintenance. These two reasons (the protection of your property and safety) must make you become aware of the importance of a regular and thorough maintenance of your boat.

The advice you will find hereafter and your **PERSONAL NOTES** will help you.

1) THE HULL

It is in laminated GRP. It is made with high quality products. However it would be wrong to assert that it will keep its original condition for life if you do not give over to it a minimum care.

The gel coat is fragile and the knocks and scratches it might have when you manoeuvre might leave marks on it. Have always a member of your crew ready to put a fender at the right place.

It will be useful to hose off the hull and deck with fresh water, as often as you can.

Hull Preparation

Beforehand, you may apply on the gel coat an epoxy paint ; it will protect the bottom (the careen) of your boat against the natural attacks of the sea environment.

Moreover, the bottom shall be covered with a protective antifouling paint which will prevent the adhesion of the sea vegetation.

When you apply the antifouling paint, be careful : do not paint the anodes, the heads of the electronic instruments and do not obstruct the strainers of the water intakes, in particular the strainers of the engine-cooling system.

In all events, remove the grease from the bottom and slightly hand rub down with at least # 400 grit sand paper and water.

Maintenance

In order to keep the good looking gel coat of your boat, a preventive and regular maintenance of it is necessary. For this, do not hesitate to ask your dealer who will give you advice about the methods to follow and the most appropriate products to use.

2) THE DECK

Regularly rinse the deck and deck fittings with fresh water.

Regularly scrub the deck with a mild detergent liquid.

Deck Fitting :

Regularly lubricate the blocks, sheaves, turnbuckles, winches, windlass, rails, travellers, and so on with grease or light oil.

Polish with an appropriate polish paste the stainless steels which may have small pits or superficial oxidation pits.

The Outside Teak Woodworks :

Scrub the woodworks using water.

The teak woodworks do not need any particular protection. If you just rub them down with fine sandpaper, it will renovate the look of the teak.

Plexiglass:

Rinse with fresh water. Clean them using a sponge and a cleaning product for windows.

The Rudder :

Every year have the whole steering system overhauled.

3) INSIDE

Whenever the weather makes it possible, air and ventilate regularly your boat, take off the floorboards, the berth spreads and put them vertically when you leave the boat.

Protect the inside of your boat as often as you can with the fitted curtains.

Make sure that the bilges are clean and dry.

The internal woodworks are varnished in most of our boats ; therefore you have to rinse them with fresh water and a liquid detergent, then polish them with a chamois leather.

The cleaning of the fabrics, cushions or lining of your boat depends on the materials used. Therefore you must contact a skilled specialist before you do anything.

Fresh Water System

It is possible to sterilize the tanks with Clonazone tablets (Dygerma in UK, or a product sold in your country and containing the equivalent molecule, i.e. Tosylchloramid) which are available at the Chemist's.

If the boat is not used for a long period of time, rinse the tanks and pipes with water and vinegar.

Engine

Have the whole drive system overhauled and maintained by a skilled mechanic and refer to the instructions by the engine manufacturer , These instructions are supplied with your boat.

Keep the fuel tank as full as you possibly can in order to avoid condensation.

4) RIGGING

You must examine once a year the running and standing rigging. Take advantage of this examination to maintain them.

Carefully rinse the running rigging with fresh water at the end of each season.

5) SAILS

Whenever it is possible, rinse the sails with fresh water and let them dry.

The sails cannot stand the sun and water ; therefore, unrig them whenever you can or at least protect them, using appropriate covers.

6) WINTER STORAGE**LAYING UP**

Remove from the boat all the documents of the boat, the lines which are not useful to moor the boat, the supplies, the clothes, the safety equipment, the batteries, the gas cylinder, and so on...

Have your safety equipment overhauled.

During this laying up period, draw up a complete inventory of the equipment on your boat.

PROTECTION AND MAINTENANCE**a) Inside:**

Drain the fresh water pipes and rinse them with water and vinegar.

Close the water intake seacocks (except if your boat is dried out), rinse and drain the toilets pans and pumps.

Store the sounder and speedometer heads.

Carefully drain and dry all the bilges.

Put the floorboards, the cushions and berth spreads vertically in order to favour the airing of the compartments.

b) Outside :

Rinse with plenty of water the hull, the deck, the deck fittings, lubricate all the mechanical and mobile parts.

Protect your boat with fenders and make sure that the mooring lines are taut

Fix the rudder so that it may not move

c) Engine :

Only a skilled mechanic can do the winter laying up of the engine. It will not be the same if the boat remains afloat or ashore.

ALL THESE RECOMMENDATIONS DO NOT MAKE UP AN EXHAUSTIVE CHECK LIST. YOUR DEALER WILL GIVE YOU THE ADVICE YOU NEED AND WILL CARRY OUT THE TECHNICAL MAINTENANCE OF YOUR BOAT

XV) ENVIRONMENT

Do not pour to the sea the oil you have just drained, use appropriate waste tanks.

When you fill up the engine tank, take all the precautions in order to avoid the hydrocarbon overflowing.

In the harbour, do not use the heads on board if they are not equipped with holding tanks.

The use of detergent contributes to the deterioration of the sea fauna and flora ; choose entirely biodegradable products for your cleaning operations.

Do not throw to the sea plastic bags and rubbish bags ; use the dustbins for this purpose in the places of call.

You love the sea, just as we do ; therefore help us to protect it and do not pollute it.